

We are DEVELON

We trace our roots to 1937 as one of Korea's first large scale machine plant. Throughout time we have consistently delivered exceptional products and solutions.

DEVELON is a bold name that reflects our core ambition to continue developing onwards and leaving behind a positive footprint in our world. Moving forward, we seek to be part of our customers and partners' endeavor to build a better world.

Powered by **Innovation**



©2023 HD Hyundai Infracore. All rights reserved.
HDIPBE-01-2307

Certain specification(s) are based on engineering calculations and are not actual measurements. Specification(s) are provided for comparison purposes only and are subject to change without notice. Specification(s) for your individual Develon equipment will vary based on normal variations in design, manufacturing, operating conditions, and other factors. Pictures of Develon units may show other than standard equipment.

develon-ce.com

DEVELON

SD Wheel Loaders

SD200-2

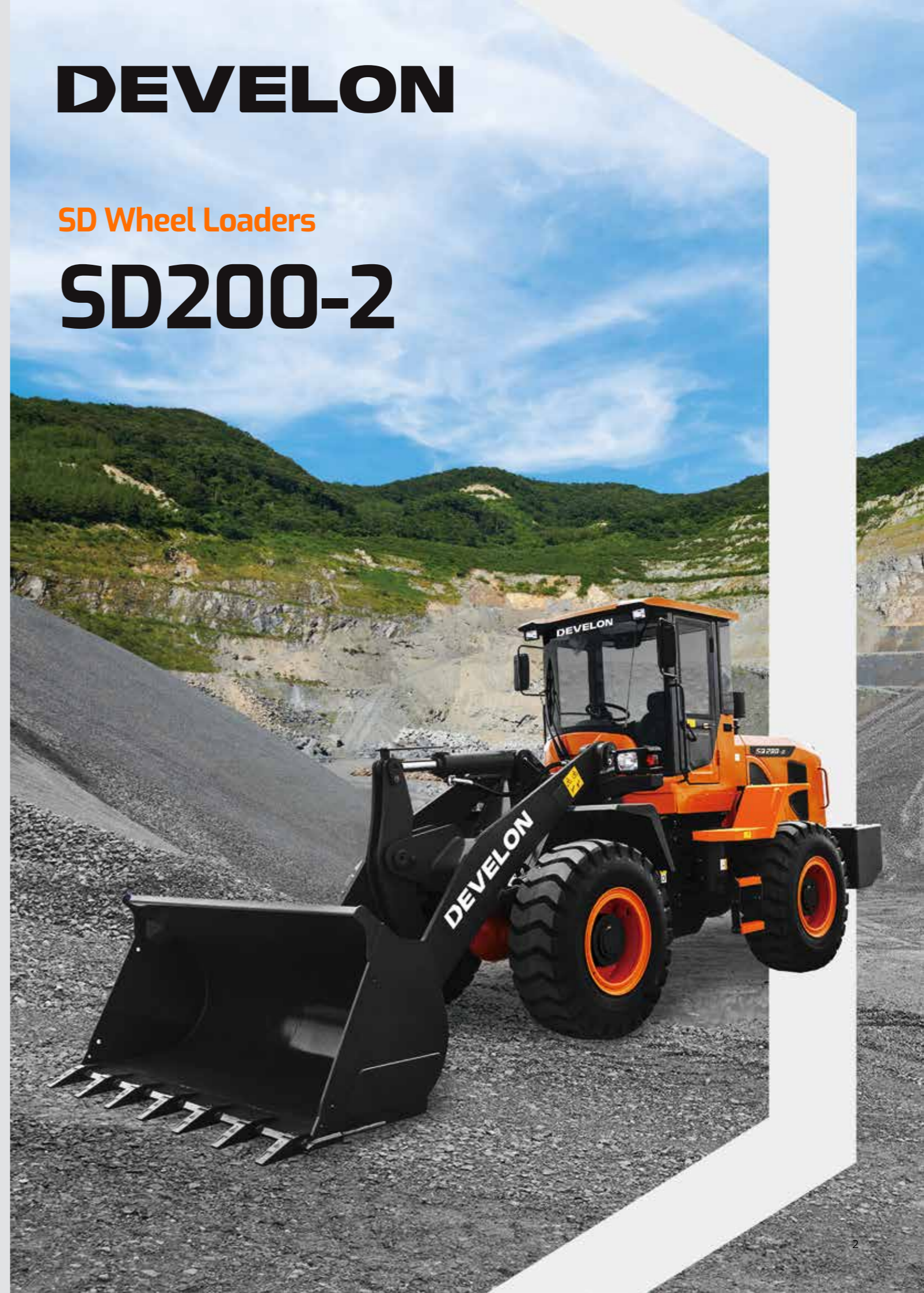

SD200-2

RELIABLE WORK HORSE

PRODUCTIVITY & PERFORMANCE

- The fixed wheel transmission boasts stable performance, high reliability and conveniently agile operation.
- Longer wheel-base and arranged design to make center of gravity positioned rearward helps SD200-2 work more stable.

RELIABILITY AND DURABILITY

- 93 dust air filter, effectively reduces the engine failure rate, realizing high efficiency and energy saving together with the large-capacity torque converter.
- The advanced Develon drive axle and improved differential gear process increased gear flexural strength, enhancing the reliability of the drive axle and extending its lifespan.



BIGGER EFFICIENCY

SMALLER TURNING RADIUS AND AGILITY

Larger steering angle (38°) makes smaller turning radius. Small turning radius offers flexibility for operator to adapt in a confined space.

PERFECTLY MATCHED POWER TRAIN

Engine, transmission and axles are optimized and finely tuned for each other and produce powerful traction.

OPTIMIZED Z BAR FRONT

Z bar front and hydraulic system is designed for heavy loads. This geometry enables rapid bucket movements, ensures correct angle positioning and good loader stability.



ENGINE (WP6G125E23)

The weichai engine is adopted for strong power and produces 92 kW at 2,300 rpm. The pumps with large displacement are equipped, which greatly increases working efficiency and decreases fuel consumption and noise, together with short total cycle time.



HANDY MAINTENANCE / OPERATOR COMFORT



EASY APPROACH

Easy approach to the filters in the engine room and brake system for simple maintenance.

DUAL FUEL FILTER

Highest efficiency filters remove water, dust & particles to protect your engine optimally. Dual fuel filters reduce the risk of external engine contamination and lengthen the engine's lifespan.

AIR CLEANER

Air cleaner for extremely dusty environment is applied to prevent dust in the desert area from permeating into the engine.

OIL LEVEL MONITOR

Used to monitor the hydraulic oil level more easily to reduce maintenance time, improving device service life-time.



ROTATING BEACON

For enhanced safety rotating beacon is equipped in SD200-2 as standard, which gives the warning alarm while driving.

FIRM AND LASTING QUALITY

REINFORCED PINS

Where workload are most severe, diameter of 6 pins is thicker than competitors by 5 ~ 10 mm

DURABLE AXLE DESIGN

More durable materials and technology were applied to machining gears.

SOLID FRAME STRUCTURE

3D CAD and FEM technologies are adopted in the analysis of technical design. Improving the strength, durability and reliability of the device.

RELIABLE HYDRAULIC COMPONENTS

This components provides delicate control, less internal leak and longer service life.

IMPROVED PIPE WELDING

New and improved welding process is applied to high pressure pipes.

TECHNICAL SPECIFICATION

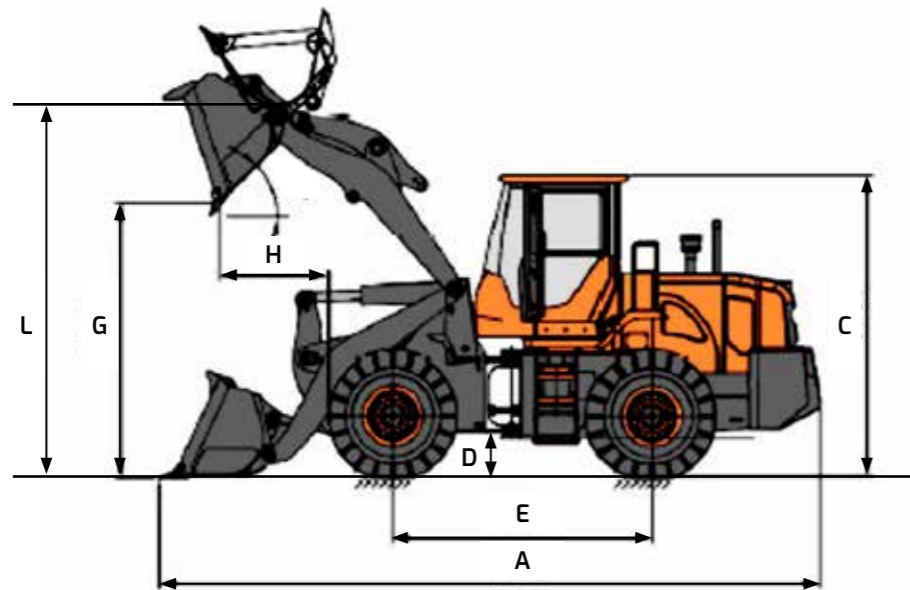

DIMENSIONS & WORKING RANGE

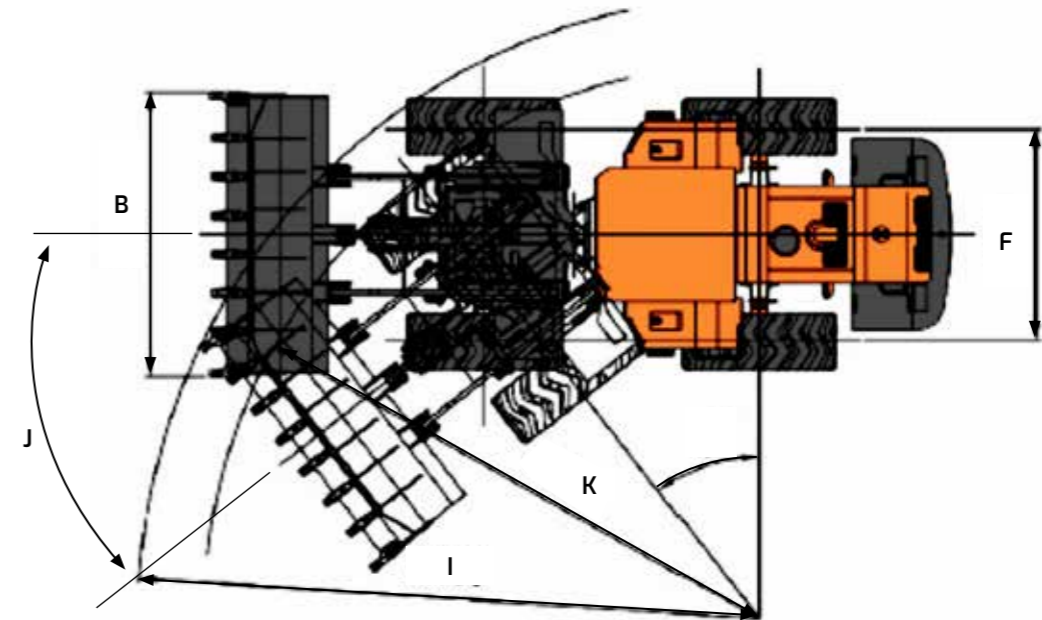

ENGINE

Model	Weichai WP6G125E23 (T2)
Rated Power (SAE J1995 Gross)	92 kW @ 2,300 rpm
Max. Torque	500 N.m

TRANSMISSION

Torque Converter	Countershaft power shift
Torque Converter Type	Single-Stage Three elements
Max. Input Torque/Max. Input Speed	650 N.m/ 2,500 r/min

GENERAL SPECIFICATIONS

Operating Weight	10,340 kg
Bucket Capacity	1.8 m ³
Breakout Force	93±7 kN
Payload	3,000 kg
Static Tipping Load (straight)	73 kN
Max. Speed	39.5 km/h
Front Speed	≤ 9.8 S, (Arm Lift < 5.9)
Max. Tractive Effort	100 kN
Axle Type	Dry type
Tire Type	Bias Tire
Tire size / Inside / PR / Pattern	17.5-25 / Tube / 12PR / Standard
Engine Cover Type	Backflip
Steering System	Articulated load-sensing hydraulic steering system
Hydraulic System Control	Pilot type

	Machine Dimensions (A*B*C)	mm	7,010 * 2,520 * 3,180	
Dimension	Overall Length	A	mm	7,010
	Overall Width	B	mm	2,520
	Overall Height	C	mm	3,180
	Ground Clearance	D	mm	370
	Wheel Base	E	mm	2,850
	Tread	F	mm	1,850
	Working Range	Dump Height	G	mm/°
Dump Reach		H	mm/°	1,040 / 45
Height at bucket pivot point		L	mm	3,795
External radius at bucket edge		I	mm	5,950
Turning Radius at tire edge		K	mm	5,370
Steering Angle		J	degree (°)	38±1
Gradeability		degree (°)	30	