

# DEVELON

Construction Equipment

## DL220-7

## DL250-7

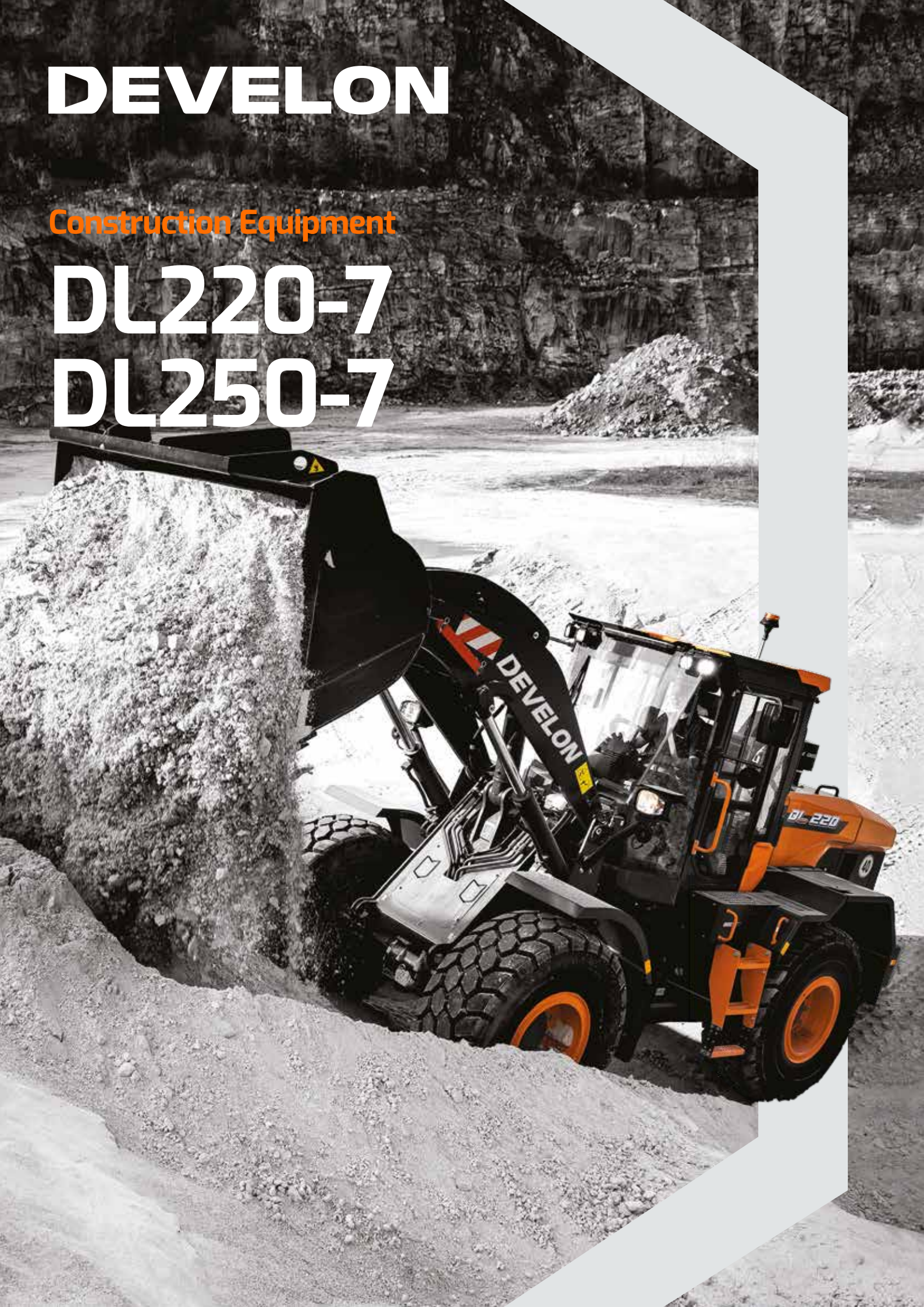





**DEVELON DL220-7 AND DL250-7  
WHEEL LOADERS:**

# **MEET THE NEW GENERATION OF DEVELON MACHINES**

Boost your productivity with the new DL220-7 and DL250-7 DEVELON wheel loaders.

Exceptional power – combined with the finest workmanship – result in machines that perform at the highest level.





# TOP PERFORMANCE AND FUEL EFFICIENCY

## ENVIRONMENT-FRIENDLY POWER

The DL220-7 and DL250-7 are powered by a DL06 engine compliant with the Stage V emissions regulations. High-pressure fuel injection and precise timing provide highly efficient fuel burn and perfect combustion. The aftertreatment system is composed of a selective catalytic reduction module, an oxidation catalyst, and a long-life particulate filter to reduce emissions without requiring an EGR (exhaust gas recirculation) valve.

## EFFICIENT POWER MANAGEMENT

You can select from 3 different engine working modes – Eco, Standard and Power – while the Power-up function lets you switch the parameters to level-up working mode with lower transmission shift intervals by fully applying the acceleration pedal.

## SAVE FUEL, SAVE MONEY

- Auto Idle  
The standard auto idle feature automatically reduces the engine revs to standby idle a few seconds after the steering wheel, gearshift control lever and accelerator cease movement. This reduces noise, improves jobsite communications and saves fuel. When you move the controls, the loader automatically returns to working idle.
- Auto Shutdown  
When enabled, the engine automatically shuts down after idle time reaches a specified elapsed time (3 to 60 minutes).

### The DL220-7 and DL250-7 enhance your output from every angle

Impressive breakout force and high traction make penetration easy and allow you to tackle the hardest materials.

- Powerful hydraulic system makes work quick and efficient.
  - DL06 engine provides the power you need while meeting Stage V environmental regulations.
- The combination of these features gives DEVELON wheel loaders excellent penetration power, ensuring optimum bucket load in each cycle.

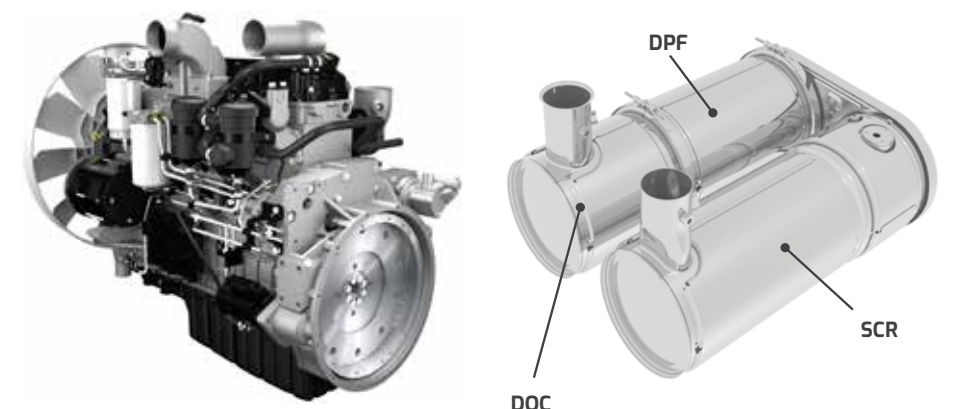





# DESIGNED FOR LONG-TERM, ALL-ROUND, HEAVY-DUTY PERFORMANCE

### POWERTRAIN

The DEVELON transmission has 5 gears to boost acceleration performance, especially on climbs with the lock-up. The gear ratios are optimized, and smooth, shock-free shifts contribute to the high overall level of operator comfort. Traction force is also maximized. Together, these qualities enable high working speed in all conditions.

### AXLE

- New stronger axle allows you to carry more.
- Limited slip differentials at the front and rear automatically ensure maximum traction and easy driving over soft and muddy ground with no need for a manual differential lock.
- Hydraulic differential lock on the front engages automatically to ensure maximum tractive effort with a lock of 100% and driving ease. Muddy and slippery areas can be navigated by the operator with the manual foot control. These features also reduce the risk of skidding and prevent excessive tire wear.
- The brake discs in the planetary reduction gears are reinforced, ensuring long hours of operation and easy maintenance access.

### ROBUST AND RELIABLE

We pay the closest attention to the design and manufacture of structural components. Finite Element Analysis is used to ensure an extended lifetime for main structures such as the chassis, joints and lift arm. Then, after modelling, they are subjected to intensive laboratory and field testing in extreme conditions. Ongoing statistical analysis is used to continually increase reliability.

### DURABLE STEEL PARTS

Rear parts – such as the radiator grille, engine hood and fenders – are made of durable steel. They're also designed for easy repair, reducing the need to replace them if they are damaged.

### EXHAUST

The inner exhaust pipe sucks air out of the engine compartment through an outer pipe – this 'chimney' effect provides constant air circulation and prevents deposits of flammable material on hot parts.

### FAST CYCLE TIMES

The entire DEVELON wheel loader lineup is carefully engineered for a perfect balance of speed and controllability – so you benefit from optimal production. Variable displacement piston pumps in all models allow DEVELON wheel loaders to power through difficult jobs with minimal fuel consumption and multifunction operation of the lift arm and bucket.

### FULL FENDERS

To keep them clean and avoid mud splashing on the windows or accidents on slippery steps, DEVELON's wheel loaders are standard equipped with full fenders and mud guards. Enlarged front fenders protect front windows and ensure maximum operator visibility.

### DRIVING ASSISTANCE

- Automatic transmission with smooth shifting
- Automatic transmission kick-down
- Automatic Hydraulic Differential Lock (HDL)
- Automatic Load Isolation System (LIS)
- Automatic kick-out function on lift arm
- Automatic return to dig position
- Automatic reversing fan
- Automatic lock-up on torque converter (available with 5-speed auto-powershift with lock-up)

## RELIABILITY – THE HABIT OF A LIFETIME

In your profession, you need equipment you can depend on. At DEVELON, we put durability and reliability at the core of our machines' development. Our materials and structures undergo stringent testing for strength and resilience under the most extreme conditions.







1. DEVELON Smart Touch
2. Intuitive gauge panel
3. Steering wheel adjustable in all directions
4. Integrated armrest with joystick
5. Control panel
6. Cup holders
7. Storage compartments
8. Premium seat with 3-point safety belt

# OPERATING IN HIGH COMFORT

## ADJUSTABLE STEERING COLUMN

Enhance your driving comfort, and work without fatigue, by easily adjusting the steering column's tilt and telescopic movements to fit your preferred position.

## DEVELON SMART TOUCH

- An easy to read and use 8" touch screen integrates all functions in one place.
- All information about the machine, settings, rear-view camera, A/C control, multimedia.
- Help function - operators can quickly and easily understand all functions without referring to the operator's manual.

## ELECTRONIC JOYSTICK

- Reduce your cycle times with fully integrated electronic joystick in right armrest. Sensitivity settings and shock prevention are designed to ensure maximum machine controllability and operator comfort. Less movement for repetitive tasks with auto-leveling function.
- Return to Dig  
Sensors on the lift arm and bucket linkage allow you to change your 'return to dig' setting from inside the cab. The cylinders and cutting edge return to the same position every time, enabling more efficient, consistent work.
  - Lift Kickout  
Set the maximum lift height for working inside buildings or other areas with height restrictions. Simply pull back on the control joystick to override.

## LUXURY CHAIR

Improved high comfortable seat with vertical and horizontal low-frequency suspension, pneumatic lumbar support, heating and 3-point safety belt with alarm icon on gauge panel and in DEVELON Smart Touch.







# TOTAL CONTROL IN ALL SIMPLICITY

### DEVELON SMART KEY

We bring automotive standards and comfort to construction machinery

- Search function
- Coming/leaving home light function
- Remote door opening
- Keyless engine start

### DEVELON SMART GUIDANCE SYSTEM

Boost your performance and reduce fuel consumption based on the system's recommendation. The machine automatically monitors and analyses driving strategy and recommends how to improve settings.

### SPACIOUS CAB

Re-designed interior offers much larger, quieter and more comfortable operator environment, which improves safety and productivity and helps the operator work with high concentration. Increased leg room with re-designed accelerator and brake pedal position. Enlarged storage area and cool-box position increase operator comfort. Improved air conditioning system, with optimized air circulation, ensures a pleasant working environment.

### VISIBILITY

Completely re-designed cab improves operator comfort and safety. Enlarged front windshield ensures better front visibility, while larger mirrors extend operator's view on the sides and rear - providing maximum safety for pedestrians and machine and improving productivity at the same time.

### COMFORTABLE AUTOMATIC LIFT ARM

Save time and reduce the number of operations with the new bucket leveling function. Automatically return the bucket to dig position from roll back or dump position. Automatic function is also available for lift arm positions.

### EASY ENTRY AND EXIT

Grab handles and offset steps with slip-resistant surfaces provide safe & easy access to the cab and easy exit when work is finished. The door opens 180° - and can be locked in the open position - to provide a wide opening for moving in and out of the machine.

## TAKE A SEAT IN BUSINESS CLASS

The ergonomic controls and the easy-to-view color monitor place the machine firmly in your hands.





# RAISE PROFITS, PRODUCTIVITY & FUEL EFFICIENCY

## STRENGTH AND INTELLIGENCE – A WINNING COMBINATION!

With tremendous lift height and capacity, along with enough torque to bite into the toughest materials, DEVELON wheel loaders go a step beyond scooping, carrying and loading. It's your ticket to making harder work easier, longer days more enjoyable, and every minute more productive and profitable.

## BOOST YOUR PRODUCTIVITY

- Ride control – Load Isolation System
- Bucket auto leveling function
- End-stroke cushioning for smooth arm and work tools movements
- Optimized shifting program

## MAXIMUM SAFETY

- Rear-view camera
- Hand rails for safe maintenance
- Up to 12 LED working lights available
- Rear-view mirrors with electric adjustment possibility
- 3-point safety belt

## READY FOR VERSATILITY

- Attachments fully tailored for application
- Wide selection of tires
- 4<sup>th</sup> spool valve available

## MAXIMIZE YOUR UPTIME

- Massive frame
- Wide fin radiator and reversible fan
- DEVELON Fleet Management

## BUSINESS CLASS OPERATOR COMFORT

The new spacious cab offers an operator-friendly environment with top-class all-round visibility. It centers around a high comfortable seat with 3-point safety belt for maximum operator safety. The joystick is fully integrated in the seat's right armrest. The electrically adjustable rear mirror contributes to maximum operator comfort.

## ALL-IN-ONE FOR BETTER PERFORMANCE

All important functions are easily accessible on the DEVELON Smart Touch

- Machine settings
- Rear-view camera
- Radio
- HVAC
- DEVELON Smart Guidance

## BETTER FUEL EFFICIENCY

The DL220-7 and DL250-7 are equipped with a powerful, new engine with low fuel consumption - without requiring an EGR (exhaust gas recirculation) valve.

## I.C.C.O. (INTELLIGENT CLUTCH CUT-OFF)

Need more engine power for lift arm speed? In lower gears, simply depress the left brake pedal to disengage the transmission. Disengage transmission cutout with your switch panel to start moving on an incline with greater ease.

## TORQUE CONVERTER WITH LOCK-UP FUNCTION

The DL220-7 and DL250-7 also feature a torque converter lockup. When this is activated, the engine automatically connects directly to the transmission (depending on speed and travel resistance), even from 2<sup>nd</sup> gear.

The transmission receives the full engine power without hydraulic slip – thus increasing speed on slope dramatically. This feature can save you up to 10% in fuel costs.

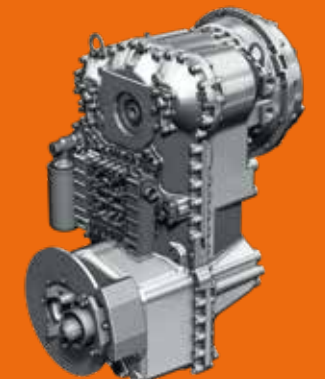





# SIMPLE MAINTENANCE WITH MAXIMUM UPTIME

## COOLING PACKAGE

Wide pitch fin radiators coupling with reversible fan keep the cooling system performing constantly - minimizing machine downtime and reducing daily maintenance.

The operator can easily set standard intervals for fan reverse from the DEVELON Smart Touch. Performance is regulated for lower fuel consumption and shorter warm-up periods.

## AIR INTAKE

Maintenance-free cyclone air pre-filter separates more than 99% of particles 20 microns in size and larger. Cleaning and cartridge replacement are only needed at long intervals. In addition to extending the air filter's lifetime, the pre-filter also ensures better combustion and a longer engine lifetime.

## WE ARE HERE FOR YOU

Boost your productivity and machine uptime with our genuine DEVELON parts; Protection+, an extended warranty covering parts, travel and service (check with your local dealer); and a maintenance contract in which your dealer supports you with routine service at regular intervals.

## FLEET MANAGEMENT

With DEVELON Fleet Management, you can proactively react to machine status, properly plan maintenance, and reduce downtime.

## SAFE ACCESS

To facilitate access and mobility on the machine, multiple platforms and hand-rails ensure that the operator always has a firm support to hold on to and 3-point contacts.





# TECHNICAL SPECIFICATIONS

## ENGINE

Designed to deliver superior performance and fuel efficiency, the DL06 diesel engine fully meets the latest Stage V emission regulations. To optimize machine performance, the engine uses high-pressure fuel injectors, air-to-air intercooler and electronic engine controls. 4-Cycle Water-Cooled, Turbocharger with wastegate, Diesel Oxidation Catalyst (DOC) & Selective Catalytic Reduction (SCR) and Diesel Particulate Filter (DPF), no Exhaust Gas Recirculation (EGR).

	DL220-7	DL250-7
Model	DL06	
No. of cylinders	6	
Displacement	5.9 l	
Max. power (SAE J1995)	119 kW/160 hp at 2100 rpm	128 kW/172 hp at 2100 rpm
Max. torque (SAE J1995)	736 Nm at 1400 rpm	804 Nm at 1400 rpm
Bore × stroke	100 × 125 mm	100 × 125 mm
Starter	24 V - 6 kW	
Batteries - Alternator	2 × 12 V - 24 V/80 A	
Air filter	Centrifugal pre-cleaner Top Spin™ Donaldson® with 2-stage dry filter	
Cooling	Cooling package with automatic reversing fan to facilitate radiator cleaning. Automatic rotation speed adjustment according to temperature conditions.	
Radiator	Wide fin radiator - Intercooler/ Hydraulic oil cooler/Transmission oil cooler	

## AXLES

Front & rear axles manufactured by ZF with outboard planetary reduction gears. 11.2 t (DL220-7) and 11.8 t (DL250-7) traction force allows operation on slopes of 30°.

	DL220-7	DL250-7
LSD lock ratio	30% (front & rear)	
HDL lock ratio	100% (front)	
Oscillation angle	+/- 11°	
Tire size - standard	20.5 R25	

## TRANSMISSION

DEVELON offer you 4 gears or as a optional 5-gear powershift transmission with torque convertor. 3 operating modes: manual, fully automatic, or semi-automatic with 'kick-down' function. Based on high-quality components. Equipped with a modulation system for protection and smooth gear and direction changes. A manual transmission control lever is located to the left of the steering wheel. Direction change function also available in automatic or semi-automatic mode. Transmission can be disengaged by the brake pedal to deliver full engine power to the hydraulic system. A safety device prevents the engine from starting if the transmission is not in neutral. 5 gear transmission is equipped with Torque converter lock-up function from 2<sup>nd</sup> to 5<sup>th</sup> gear.

	DL220-7	DL250-7
Type	4-speed auto-powershift / 5-speed auto-powershift with lock-up (as option)	
Speeds - forward 1/2/3/4	7.0 / 12.8 / 24.1 / 38.9	6.4 / 11.8 / 22.8 / 37.5
Speeds - forward 1/2/3/4/5	6.5 / 13.0 / 20.0 / 29.9 / 40.0	6.0 / 12.0 / 18.5 / 27.7 / 40.0
Speeds - reverse 1/2/3	7.4 / 13.4 / 25.3	6.8 / 12.4 / 24.0
Maximum traction (4-speed/5-speed)	11.2 t / 11.3 t	11.8 t / 13.2 t
Maximum gradeability	58% (30°)	

## HYDRAULIC SYSTEM

	DL220-7	DL250-7
Type	Load sensing closed center hydraulic system	
Main pump	Dual variable displacement axial pistons pumps	
Maximum flow	155 l/min	
Maximum pressure	250 bar	265 bar
EMCV	Automatic functions for positioning the bucket ready to dig and a function for stopping the lift arm at the desired height.	
Filtration	In the oil return to the tank, the fibre glass filter has a filtering capability of 10 micron.	

## LIFT ARM

Z-kinematics with simple lifting piston system designed for heavy-duty applications. 103 kN (DL220-7) & 117 kN (DL250-7) breakout force combined with a bucket angle that is maintained throughout the range of movement. Bucket angles are optimized in the travelling position and at ground level. Load Isolation System (LIS) is fitted as standard for improved operator comfort, output and lifetime.

Load cycle	DL220-7	DL250-7
Lift arm - up	6.2 s	6.3 s
Lift arm - down	3.7 s	3.5 s
Bucket - dump	1.5 s	1.6 s

## HYDRAULIC CYLINDERS

High-strength steel piston rods and cylinder bodies. Shock-absorbing mechanism fitted in all cylinders for shock-free operation and extended piston life.

Cylinders	Quantity	Bore × rod diameter × stroke (mm)	
		DL220-7	DL250-7
Lift	2	115 × 75 × 790	
Bucket	1	130 × 80 × 515	135 × 80 × 515

## BRAKES

Dual multi-disc circuit with sintered metal discs for extended service life. Braking system activated by a pump and accumulator circuits. Spring-applied, hydraulically released parking brake is mounted on the transmission shaft and accumulator circuits and is electronically activated. Brake type: spring-applied / hydraulically released. Brake pump with variable displacement axial pistons provide 37.8 l/min. Operator can activate/deactivate the Clutch Cut Off on the brake pedal from a switch and can adjust the sensor proximity with the same switch. The emergency brakes are composed of a double system continually under pressure by accumulators.

	DL220-7	DL250-7
Braking distance	6.1 m at 32 km/h	6.3 m at 32 km/h

## CAB

Safety compliance with Roll Over Protection System (ROPS) and Falling Object Protective Structure (FOPS) requirements. Spacious modular cab with excellent all-round visibility and ample storage space. Good overview of the bucket, tires and loading area thanks to wide windows. Pushbutton controlled air conditioning and heating with air recirculation function. Double cab air filter installed in the cab with extra protection for the operator in dusty or polluted environments. Vis-cous suspension mount for maximum comfort. Adjustable high-quality heated seat with air suspension, arm rests and height and tilt adjustable steering column. All operating information clearly displayed in front of the operator. Control functions are centralized on a console on the right.

	DL220-7	DL250-7
Safety standards	ROPS ISO 3471:2008 FOPS ISO 3449	

## NOISE EMISSIONS

Noise emissions	DL220-7	DL250-7
Operator sound pressure level (ISO 6396)	72 dB	
Exterior sound power level (ISO 6395)	104 dB	

## FLUID CAPACITIES

	DL220-7	DL250-7
Fuel tank	235 l	
DEF (AdBlue®) tank	30 l	
Cooling system (radiator)	34 l	
Engine oil	24,5 l	
Front axle	23 l	
Rear axle	23 l	
Transmission oil	32 l	
Hydraulic system	120 l	
Hydraulik tank	85 l	



# PERFORMANCE DATA & DIMENSIONS

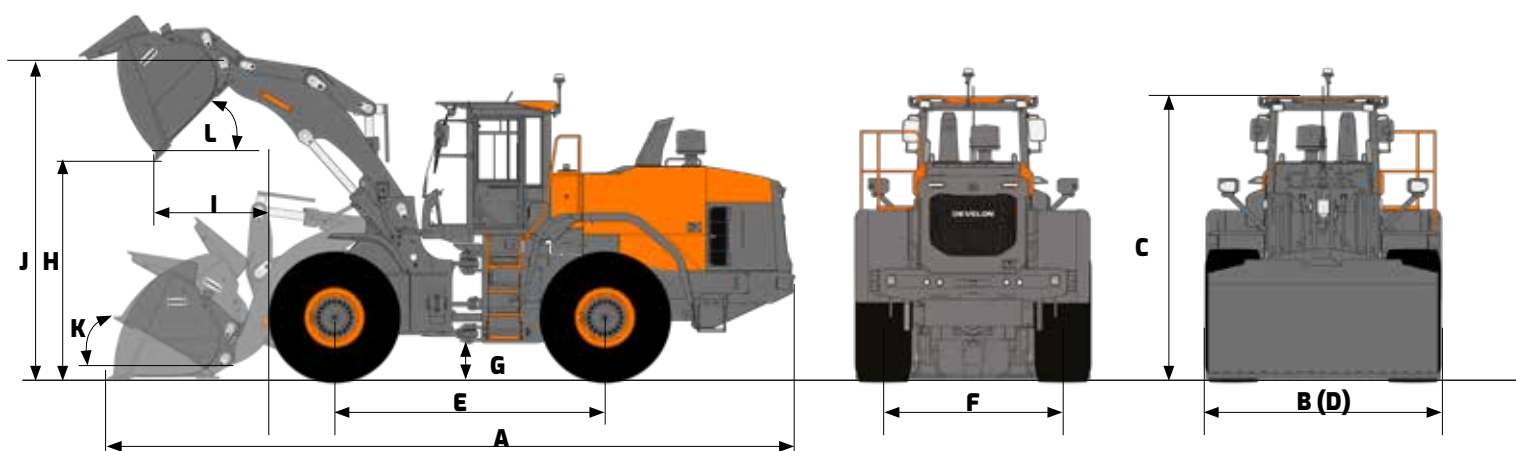

DL220-7

Pin-on	Unit	Eco bucket		Performance bucket				High lift
		General purpose		General purpose		Material handling		
		2.2 m <sup>3</sup> TEETH	2.3 m <sup>3</sup> BOCE	2.5 m <sup>3</sup> BOCE	2.4 m <sup>3</sup> TEETH	2.5 m <sup>3</sup> BOCE	2.4 m <sup>3</sup> TEETH	
Ground engaging tools								
Capacity heaped ISO/SAE	m <sup>3</sup>	2.2	2.3	2.5	2.4	2.5	2.4	=
Capacity at 110% fill factor	m <sup>3</sup>	2.4	2.5	2.8	2.6	2.8	2.6	=
B Bucket width	mm	2550	2550	2550	2550	2550	2550	=
Breakout force	kN	103	97	91	96	96	102	=
Static tipping load (straight)	kg	10709	10652	10390	10440	10472	10557	-1704
Static tipping load (full turn - 40°)	kg	9440	9383	9125	9175	9204	9288	-1502
H Dump height (at 45° - fully raised)	mm	2710	2784	2741	2664	2779	2702	+481
I Dump reach (at 45° - fully raised)	mm	1068	1010	1042	1144	1009	1110	+10
Digging depth	mm	67	61	66	42	66	42	+66
J Height at bucket pivot point	mm	3853	3853	3853	3853	3853	3853	+449
Max. tilt angle in carry position	°	47	47	45	45	45	45	+3
Max. tilt angle fully raised	°	59	59	59	59	59	59	+2
K Max. tilt angle on ground	°	43	43	41	40	41	40	+1
Max. tilt angle at max. reach	°	59	59	59	59	59	59	-1
L Max. dump angle fully raised	°	48	48	48	48	48	48	-2
Max. dump angle at max. reach	°	65	65	65	65	65	65	-5
Max. dump angle on ground	°	64	64	64	64	64	64	-1
External radius - bucket edge	mm	6058	6016	6040	6085	6019	6063	+179
External radius - tire side	mm	5502	5502	5502	5502	5502	5502	=
E Wheel base	mm	3050	3050	3050	3050	3050	3050	=
D Width at tires edge	mm	2539	2539	2539	2539	2539	2539	=
F Tread	mm	1930	1930	1930	1930	1930	1930	=
G Ground clearance (at 12° osc.)	mm	434	434	434	434	434	434	=
A Overall length	mm	7557	7458	7515	7618	7465	7568	+393
C Overall height	mm	3313	3313	3313	3313	3313	3313	=
Operating weight	kg	13140	13198	13430	13379	13377	13291	+166

All capacities according ISO 7546, with straight blade [measure at the tip of bucket teeth or cutting edge], tires Bridgestone 20.5 VJT (L3), base EU configuration.



DL250-7

Pin-on	Unit	Eco bucket		Performance bucket				High lift
		General purpose		General purpose		Material handling		
		2.4 m <sup>3</sup> TEETH	2.5 m <sup>3</sup> BOCE	2.7 m <sup>3</sup> BOCE	2.6 m <sup>3</sup> TEETH	2.7 m <sup>3</sup> BOCE	2.6 m <sup>3</sup> TEETH	
Ground engaging tools								
Capacity heaped ISO/SAE	m <sup>3</sup>	2.4	2.5	2.7	2.6	2.7	2.6	=
Capacity at 110% fill factor	m <sup>3</sup>	2.6	2.8	3.0	2.9	3.0	2.9	=
B Bucket width	mm	2740	2740	2550	2550	2550	2550	=
Breakout force	kN	117	116	99	104	104	110	+1
Static tipping load (straight)	kg	11128	11015	10800	10851	10888	10938	-1783
Static tipping load (full turn - 40°)	kg	9809	9696	9490	9540	9574	9624	-1572
H Dump height (at 45° - fully raised)	mm	2679	2762	2696	2620	2734	2657	+482
I Dump reach (at 45° - fully raised)	mm	1082	1017	1082	1184	1048	1150	+11
Digging depth	mm	77	71	66	42	66	42	+66
J Height at bucket pivot point	mm	3853	3853	3853	3853	3853	3853	+449
Max. tilt angle in carry position	°	47	47	45	45	45	45	+3
Max. tilt angle fully raised	°	59	59	59	59	59	59	+2
K Max. tilt angle on ground	°	43	43	41	40	41	40	+1
Max. tilt angle at max. reach	°	59	59	59	59	59	59	-1
L Max. dump angle fully raised	°	48	48	48	48	48	48	-2
Max. dump angle at max. reach	°	65	65	65	65	65	65	-5
Max. dump angle on ground	°	64	64	64	64	64	64	-1
External radius - bucket edge	mm	6161	6115	6066	6111	6045	6089	+178
External radius - tire side	mm	5502	5502	5502	5502	5502	5502	=
E Wheel base	mm	3050	3050	3050	3050	3050	3050	=
D Width at tires edge	mm	2539	2539	2539	2539	2539	2539	=
F Tread	mm	1930	1930	1930	1930	1930	1930	=
G Ground clearance (at 12° osc.)	mm	434	434	434	434	434	434	=
A Overall length	mm	7597	7487	7575	7678	7525	7628	+392
C Overall height	mm	3313	3313	3313	3313	3313	3313	=
Operating weight	kg	13732	13847	13989	13938	13936	13885	+165

All capacities according ISO 7546, with straight blade [measure at the tip of bucket teeth or cutting edge], tires Bridgestone 20.5 VJT (L3), base EU configuration.



Certain specification(s) are based on engineering calculations and are not actual measurements. Specification(s) are provided for comparison purposes only and are subject to change without notice. Specification(s) for your individual Develon equipment will vary based on normal variations in design, manufacturing, operating conditions, and other factors. Pictures of Develon units may show other than standard equipment

# Powered by Innovation

[develon-ce.com](https://develon-ce.com)

Construction Equipment  
HDIPBE-01-2304

©2023 HD Hyundai Infracore. All rights reserved. ©2023 HD Hyundai Infracore. All rights reserved.

