

# DEVELON

Articulated Dump Truck

# DA30/DA45



# TAKE A TOUR OF THE DA30

## PRODUCTIVITY

The DA30 offers best-in-class ground clearance & ground bearing pressure. Combined with superior torque at low engine RPM, and superior power and traction, we offer you the best productivity.

## OPERATOR'S ENVIRONMENT

Ergonomic controls, most spacious cab in the market, high-class seat, Bluetooth radio with USB, and much more....

## OPERATE AT EASE

Upgraded monitor panel, new control panel for more convenient use, real-life payload meter with external light indication, rear-view camera, body tip boost button, etc.

## POWER

Scania DC 09 engine: 276 kW (375 HP) at 2100 rpm with electronic exhaust brake..

## NEW QUALITY OF RIDE

New self-leveling, hydro-gas suspension supports soft ride in harsh conditions.

## MANEUVERABILITY

Unique design of rear frame, body, and front-mounted differential on transmission make the DEVELON machine the most compact ADT in its class, which results in smallest turning radius and outstanding stability.

## DIFFERENTIAL

Front and rear differentials are limited slip, longitudinal differential can be manually locked by pushing 1 button.



## SERVICE ACCESSIBILITY

Diesel and grease (for auto-lube system) filling from ground level. Easy access to filters and oil filling points. Tilttable cab with self-positioning locking mechanism.

## SAFETY HIGHLIGHTS

Gradient meter with body flip-over protection, Body Over Centre of Gravity function, fenders and hand rails all around cab, superior stability and always visible and clean front cab access.

## BODY

Steel plates with 400 HB hardness. Capacity without/with tailgate : 16.8/17.8 m<sup>3</sup>. Tailgate, body heating & wear plates available as optional equipment.

## DEVELON FLEET MANAGEMENT Telematics Service (OPTIONAL)

Monitor your fleet online. As standard, DEVELON Connect system with dual mode (satellite, GSM). Check productivity, fuel consumption, system warnings, maintenance status, etc.

## BRAKE SYSTEMS

Oil-cooled wet disc brakes (lifetime up to 15,000 hours). Standard hydraulic transmission retarder & hydraulic parking brake.

# TAKE A TOUR OF THE DA45

## PRODUCTIVITY

The DEVELON DA45 offers the best combination of payload and efficiency in its class. Thanks to its unique design, best productivity is delivered in all working conditions.

## OPERATE AT EASE

Upgraded monitor panel, new control panel for more convenient use, real-life payload meter with external light indication, rear-view camera, body tip boost button, etc.

## OPERATOR'S ENVIRONMENT

Ergonomic controls, most spacious cab in the market, high-class seat, Bluetooth radio with USB, and much more....

## POWER

Scania DC13 water-cooled diesel engine with turbo charger and air to air intercooler (368kw at 2100rpm).

## NEW QUALITY OF RIDE

New self-leveling, hydro-gas suspension supports soft ride in harsh conditions.

## MANEUVERABILITY

Unique design of rear frame, body, and front-mounted differential on transmission make the DEVELON machine the most compact ADT in its class, which results in smallest turning radius and outstanding stability.

## DIFFERENTIAL

Front and rear differentials are limited slip, longitudinal differential can be manually locked by pushing 1 button.

## SAFETY HIGHLIGHTS

Gradient meter with body flip-over protection, Body Over Centre of Gravity function, fenders and hand rails all around cab, superior stability and always visible and clean front cab access.

## BODY

Steel plates with 400 HB hardness. Capacity without/with tailgate : 24.5/26.1 m<sup>3</sup>. Tailgate, body heating & wear plates available as optional equipment.

## DEVELON FLEET MANAGEMENT Telematics Service (OPTIONAL)

Monitor your fleet online. As standard, DEVELON Connect system with dual mode (satellite, GSM). Check productivity, fuel consumption, system warnings, maintenance status, etc.

## BRAKE SYSTEMS

Oil-cooled wet disc brakes (lifetime up to 15,000 hours). Standard electronic engine brake, hydraulic transmission retarder & parking brake.

## SERVICE ACCESSIBILITY

Diesel, AdBlue (T4F only) and grease (for auto-lube system) filling from ground level. Easy access to filters and oil filling points. Tilttable cab with self-positioning locking mechanism.



# TOP PERFORMANCE AND FUEL EFFICIENCY



## THE POWER TO RAISE PRODUCTIVITY

The DEVELON ADT concept offers a larger load capacity in all weight categories. Additional load capacity, combined with superior power and traction, improve productivity. The unique advantages of the DEVELON ADT's permanent 6-wheel drive, free-swinging rear tandem, front-mounted turning ring, independent front wheel suspension, and sloping rear frame provide excellent driving stability with equal weight distribution and superior traction. The DEVELON Articulated Dump Truck is designed to work under very tough conditions and travel up to 55 km/h.



## ENGINES – LOWER EMISSIONS / SAME GREAT PERFORMANCE

DEVELON ADTs use only proven, reliable and powerful diesel Scania engines with excellent torque, which achieve low fuel consumption and meet Tier2/3/4F regulation requirements.

## NEW SELF-LEVELING HYDRO-GAS FRONT SUSPENSION

The DA30's design was based on the successful and proven design of the DA45. It has been upgraded with the self-leveling system for better shock absorption in changing operating conditions.

## PAYLOAD METER

Our standard real-life payload & load count meter provides the DEVELON operator and owner with an immediate indication of the productivity. External indication lights help load the body more efficient.

## DOWNHILL SPEED MODULATION

Powerful hydraulic retarder keeps machine's speed constant on downhills without support of service brakes. Operator can easily adjust the retarder's power by lever or simply pushing the gas pedal.

## DESIGN SIMPLICITY

Permanent 6-wheel drive, together with the ground-following rear tandem and our special front-mounted turning ring, provide equal power & weight distribution and excellent operating performance. The sloping rear frame provides a lower centre of gravity - improving the ADT's overall stability, and ensuring fast and easy tipping of the body for increased productivity.

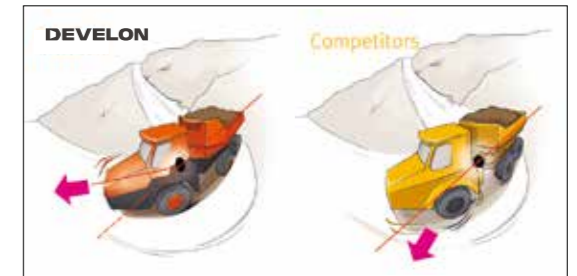

## TRANSPORTABILITY

Thanks to its less than 3-meter width, the DA30 can be moved easily from one site to another. And thanks to the compact design of both machines, a shorter low loader can be used.

## FORWARD-MOUNTED TURNING RING

The turning ring is located in front of the articulation point, ensuring equal weight distribution to the front wheels in all operating situations, including maximum turning. The equal weight distribution enables you to use the limited slip differentials with only 45% locking value - ensuring drive to both front wheels in all situations, without completely locking the wheels.

## TRACTION

The DEVELON ADT's unique design offers permanent 6-wheel drive, ensuring stability and equal weight distribution to accommodate all job applications. The DEVELON ADT's superior driveline ensures maximum traction and durability.

- Front-mounted articulation hinge
- 1 manual differential lock
- 2 limited-slip differentials
- Sloping rear frame
- Gear-driven tandem axle



\* The above image may differ from the actual product.

# OPERATE IN COMFORT

## THE QUIETEST TRUCK IN THE INDUSTRY

The spacious ROPS/FOPS cab is equipped with climate control and a high-quality operator seat with air suspension to provide excellent comfort. Precise steering, good visibility, low noise levels (71dB ISO 6396) and optional vertical movement provide additional comfort and quiet.

- The sloping hood gives the operator an excellent view
- The cab is mounted on a special rubber suspension to reduce vibration and conduction of noise into the cab



Sliding window and hand grip

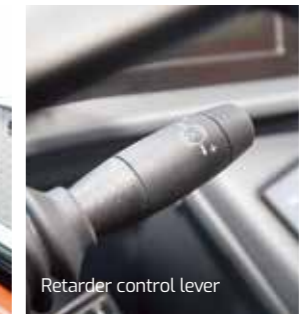

Retarder control lever



Safety hand rails all around the cab

## BEST-IN-CLASS OPERATOR ENVIRONMENT

The cab was designed based on the feedback received directly from hundreds of DEVELON operators. This resulted in upgrade of the cab in features and functions required by the market, including: hand grip on the right side, foot rest, improved storage room, USB charger, Bluetooth radio, all around rails outside the cab, additional lever for retarder control and a number of other new features.

## HIGH-COMFORT AIR-SUSPENSION SEAT

Because a highly comfortable seat means a lot to every operator, we provide an air-suspension seat with armrest as standard.

## ONE KEY SOLUTION

To enter and safely operate your DEVELON ADT, you need just 1 key to lock and unlock all the doors and also start the engine.

## SELF-LEVELING, HYDRO-GAS FRONT SUSPENSION

New suspension system has outstanding performance in rough terrain due to big shock absorption capacity of the hydraulic suspension cylinders. On top of that, the self-leveling system can adjust to match changing working conditions.

## STORAGE COMPARTMENTS WITH EXTRA 12V POWER SUPPLY

Plenty of storage spaces, plus extra room designed to fit cool/hot box with additional 12V power supply.

## MP3, DAB AND BLUETOOTH

Standard radio supports all modern features like MP3, DAB and Bluetooth

## CLIMATE CONTROL

Our specially designed climate control is easy to operate and highly efficient - keeping you comfortable at all times.

# TOTAL CONTROL IN ALL SIMPLICITY

## OPERATE AT EASE IN YOUR COMFORT ZONE

The DEVELON ADT is one of the industry's simplest trucks to operate and, at the same, time offers a large number of functions. Comfortably seated in this class-leading operator cab, you'll enjoy easy operation combined with excellent efficiency. And thanks to the upgraded monitor panel, you'll operate in your comfort zone.

- Bigger indications
- Multiple languages
- Integrated payload meter (as standard)
- Diagnostic section with transmission and hydraulic oil level check function
- Gradient meter indication for increased safety while operating
- Integrated rear-view camera (as standard)

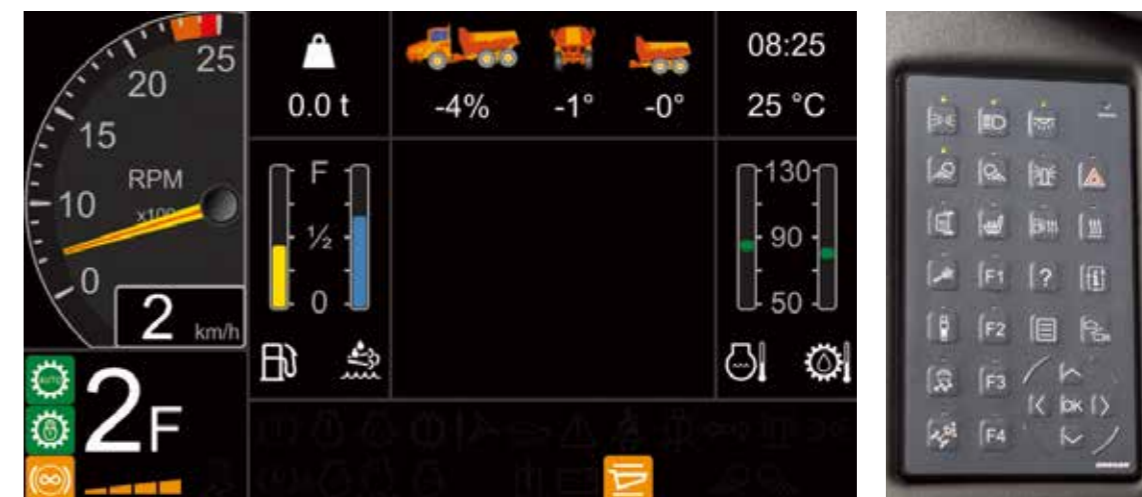

## LCD COLOR MONITOR PANEL

- 7" color display, resolution 800 x 480 pixels
- Shows all necessary information for driving and handling the machine
- Rear-view camera image embedded in instrumentation graphics
- Backlight dimming according to ambient light conditions
- Sub-menus for additional and diagnostic functions

## BODY HOIST LEVER

The new body hoist lever is easy to operate and fingertip controlled. This electronically managed hoist lever incorporates a higher body up speed and an automatic body down feature, with soft touch down, to keep you safe at all times.

## "TIP-TRONIC" GEAR SHIFT

To ensure the smoothest possible gear shifts and momentum, you can run the truck in both automatic and manual gears.

## TOUCH PAD

- Diesel fuel heater
- Longitudinal differential lock
- Override button
- Cab roof and mirror arm front lights
- Hazard lights
- Operating work-lights

## RETARDER FORCE MODULATION LEVER

New lever located on the right-hand side below the steering wheel enables operator to choose from 4 power modes. On top of that, the gas pedal is responsible for retarder power reduction.

## DIFFERENTIAL ACTIVATION

With automatic limited slip differentials, automatic and manual transmission shift, power steering, "simple touchpad" and "easy to read" display, every ADT is as simple to use & operate as possible.



Body hoist lever with boost button



All-round visibility

# SIMPLE MAINTENANCE WITH GREAT UPTIME

## ACCESS MAIN FILLING POINTS WHILE STANDING ON THE GROUND

Improved simplicity of maintenance and service reduces failure rate and improves lifetime and longevity. Convenient position of liquids' levels check and filling points, easy access to filters and very low number of rubber wearing components significantly reduce labor time.



- Easy access to factory-fitted standard automatic central lubrication system
- Dedicated space for grease cartridge and grease gun.
- Easy access to filters
- Diesel and AdBlue (T4F only) filling points accessible from the ground level
- Diesel tank prepared for fast fill coupler
- LED light indicates when power isolator can be switched off
- Power isolator in convenient and safe location
- External power supply



- Multifunctional display with available service / maintenance functions
- Transmission oil level check
- Status of hydraulic and electronic components

## FILTERS

All filters are centralized for quicker and easier accessibility.

## GLOBAL DEVELON NETWORK

With a network of DEVELON Dealers & Parts Distribution Centers worldwide, your DEVELON trucks can be serviced & maintained wherever you are.

## TELEMATICS

The DEVELON Connect system is available for reading out vehicle operating & production parameters remotely, and providing you with total ease-of-mind. Keep day-by-day overview on the machine's productivity, status and condition.



\* The above image may differ from the actual product.

# DEVELON FLEET MANAGEMENT Telematics Service (OPTIONAL)

**TELECOMMUNICATIONS** Data flow from machine to web



### TELEMATICS TERMINAL

Terminal device is installed and connected to a machine to get machine data.



### TELECOMMUNICATION

DEVELON provides Dual mode (Cellular, Satellite) communication to maximize communication coverage



### Develon FM WEB

User can monitor machine status from DEVELON FM Web

**TELEMATICS SERVICE BENEFITS** Develon and dealer support customers to improve work efficiency with timely and responsive services

#### CUSTOMER

- Improve work efficiency
- Timely and preventive service
- Improve operator's skills by comparing work pattern
- Manage fleet more effectively

#### DEALER

- Better service for customers
- Provide better quality of service
- Maintain machine value
- Better understanding of market needs

#### DEVELON

- Responsive to customer's voice
- Utilize quality-related field data
- Apply customer's usage profile to develop new machine

**FUNCTIONS(WEB/APP)** Develon Telematics Service provides various functions to support your great performance



GPS



Fuel information



Preventive maintenance



Operation hours



Fault code/warning



ADT Productivity



Reports

FUNCTION		EXCAVATOR	WHEEL LOADER	ADT
GPS	Location Geo-fence	All models	All models	All models
Operation hours	Daily, Weekly, Monthly report	All models	All models	All models
Operation hours	Total operation hours Operation hours by mode	All models	All models	All models
Maintenance parts	Preventive maintenance by item replacement cycle	All models	All models	All models
Fault code/ Warning	Fault code Machine Warnings on Gauge Panel	All models	All models	All models
Fuel information	Fuel level Fuel consumption	All models	All models	All models
Dump capacity	Dump tonnage Count of Work Cycle	N/A	N/A	All models

# GLOBAL PARTS NETWORK

## QUALITY-PROVEN MAIN COMPONENTS

DEVELON provides fast and precise worldwide delivery of genuine DEVELON parts through its global PDC (parts distribution center) network.



### GLOBAL NETWORK

The global network of the GPDC (Global Parts Distribution Center) maximizes its fill rate by making sure that each center is stockpiled with all the critical parts required for businesses in its area. The network also minimizes the time and costs required for parts delivery by positioning PDCs close to major markets around the world. DEVELON PDCs communicate with customers in their time zone, informing them that they are open for operation, and deliver parts to them as early as possible.

## THE GLOBAL PARTS DISTRIBUTION CENTER NETWORK

PDCs had been set up as shown below, including Mother PDC in Ansan, Korea. The nine other PDCs include one in China (Yantai), three in USA (Atlanta, Seattle and Miami), two in Europe (Germany and the UK), one in the Middle East (Dubai) and two in Asia (Singapore and Indonesia).



MPDC : Mother Parts Distribution Center

PDC : Parts Distribution Center

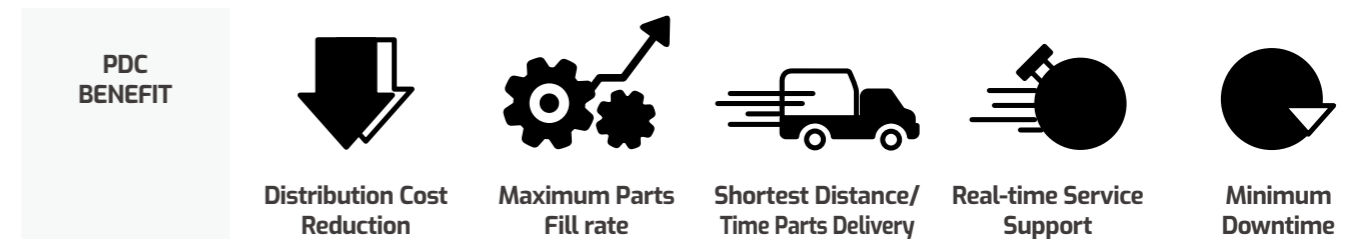



# TECHNICAL SPECIFICATIONS

## DA30

### BODY

#### Body volume (without Tailgate)

16.8 m<sup>3</sup> – 22.0 yd<sup>3</sup>

#### Material

Hardened abrasion-resistant steel plates (400 HB)

#### Tilt cylinders

Single stage, double-acting

#### Tipping time

Up: 12 sec. / Down: 10 sec.

#### Body

Designed for exhaust heating

#### Sloping frame

Down from the hinge point

#### Level capacity (with/without tailgate)

14.2 m<sup>3</sup> / 13.6 m<sup>3</sup> – 18.6 yd<sup>3</sup> / 17.8 yd<sup>3</sup>

#### Heaped capacity (with/without tailgate)

17.8 m<sup>3</sup> / 16.8 m<sup>3</sup> – 23.3 yd<sup>3</sup> / 22.0 yd<sup>3</sup>

### ELECTRICAL SYSTEM

#### Batteries

2 x 12V 105Ah (series connected to give 24V)

#### Starter

6KW (8HP)

#### Alternator

24 V 100A

### WEIGHTS

#### Empty : Front axle

12700 kg – 27558 lb

#### Empty : Rear axle

10600 kg – 23369 lb

#### Max. admissable axle load: Front axle

16700 kg – 36817 lb

#### Max. admissable axle load: Rear axle

37000kg – 81571 lb

#### Max. admissable weight

51200 kg – 112877 lb

#### Payload

28 metric ton – 31 short ton

#### Net weight

23200 kg – 51147 lb

#### NOTE: All weights include a full fuel tank and operator

### GROUND PRESSURE

#### Ground pressure

Standard 23.5 x 25 tires with 15% sinkage

#### Empty : Front axle

121.7 kPa – 17.65 psi

#### Empty : Rear axle

51.6 kPa – 7.48 psi

#### Loaded : Front axle

161.6 kPa – 23.44 psi

#### Loaded : Rear axle

169.8 kPa – 24.63 psi

### CAPACITIES

#### Fuel tank

362 l

#### Hydraulic tank

63 l

#### Adblue tank (T4F only)

70 l

#### Hub front

9.6 (2) l

#### Tandem housing, rear differential and hubs

155 (2) l

#### Cooling circuit

45 l

#### ENGINE

35 l

### ENGINE

#### Complies with Tier2, Tier4F emission

Scania DC 9, water-cooled, diesel engine with turbo charger and air-to-air intercooler

#### Power rating ISO 3046 @ 2100 rpm

Tier2 375 hp (267kW) / Tier4F 375 hp (276kW)

#### No. of cylinders

5 (in line)

#### Gross torque

1873 Nm @ 1300 rpm

#### Cylinder volume

9.3 litres

#### Bore diameter x stroke

130 x 140 mm

#### Air filter

Dry type

### SPEEDS

#### Speeds

Forward – Reverse

#### Forward1 – 2 – 3 – 4 – 5 – 6 – 7 – 8

6 - 8 - 11 - 16 - 23 - 32 - 45 - 55 km/h

#### Reverse1 – 2 – 3 – 4

6 - 8 - 11 - 16 km/h

### TRANSMISSION

Electronically-controlled automatic transmission with retarder. The torque converter has automatic lock-up in all gears.

ZF 8 EP320

### HYDRAULIC SYSTEM

1 variable displacement piston pump for steering & tipping for cooling fan, brakes & auxiliaries

305 l / min @ 2100 rpm

#### Filtration

One return flow filter

#### Main safety valves pressures, tipping / steering circuit

280 / 210 bar

### TIRES

#### Standard

23.5 R25 Tubeless, two star radial

# TECHNICAL SPECIFICATIONS

## DA45

### BODY

#### Body volume (without Tailgate)

24.6 m<sup>3</sup> – 31.9 yd<sup>3</sup>

#### Material

Hardened abrasion-resistant steel plates (400 HB)

#### Tilt cylinders

Single stage, double-acting

#### Tipping time

Up: 10 sec. / Down: 10 sec.

#### Body

Designed for exhaust heating

#### Sloping frame

Down from the hinge point

#### Level capacity (with/without tailgate)

20.4 m<sup>3</sup> / 19.6 m<sup>3</sup> – 26.7 yd<sup>3</sup> / 25.6 yd<sup>3</sup>

#### Heaped capacity (with/without tailgate)

26.1 m<sup>3</sup> / 24.6 m<sup>3</sup> – 47.1 yd<sup>3</sup> / 31.9 yd<sup>3</sup>

### ELECTRICAL SYSTEM

#### Batteries

2 x 12V 105Ah (series connected to give 24V)

#### Starter

6KW (8HP)

#### Alternator

24 V 100A

### WEIGHTS

#### Empty : Front axle

14500 kg – 31967 lb

#### Empty : Rear axle

16000 kg – 35274 lb

#### Max. admissable axle load: Front axle

22500 kg – 49604 lb

#### Max. admissable axle load: Rear axle

55000 kg – 121254 lb

#### Max. admissable weight

71500 kg – 156749 lb

#### Payload

41 metric ton – 45 short ton

#### Net weight

30500 kg – 66359 lb

NOTE: All weights include a full fuel tank and operator

### GROUND PRESSURE

#### Ground pressure

Standard 29.5 x 25 tires with 15 % sinkage

#### Empty : Front axle

93.9 kPa – 13.62 psi

#### Empty : Rear axle

51.8 kPa – 7.51 psi

#### Loaded : Front axle

139.2 kPa – 20.19 psi

#### Loaded : Rear axle

161.3 kPa – 23.39 psi

### CAPACITIES

#### Fuel tank

491 l

#### Hydraulic system

63 l

#### AdBlue tank (T4F only)

70 l

#### Hub front

9.6 (2)

#### Tandem housing, rear differential and hubs

228 (2)

#### Cooling circuit

50

#### ENGINE

45

### ENGINE

#### Complies with Tier 2 / 3 / 4F emissions

Scania DC 13, water-cooled, diesel engine with turbo charger and air-to-air intercooler

#### Power rating ISO 3046 @ 2100 rpm

Tier2 500 hp (368kW) / Tier3 450 hp (331kW) / Tier4F 500 hp (368kW)

#### No. of cylinders

6 (in line)

#### Gross torque

2373 Nm @ 1300 rpm

#### Cylinder volume

12.7 litres

#### Bore diameter x stroke

130 x 160mm

#### Air filter

Dry type

### SPEEDS

#### Speeds

Forward – Reverse

#### Forward1 – 2 – 3 – 4 – 5 – 6 – 7 – 8

6 - 9 - 12 - 17 - 24 - 34 - 48 - 55 km/h

#### Reverse1 – 2 – 3 – 4

6 - 9 - 12 - 17 km/h

### TRANSMISSION

Electronically-controlled automatic transmission with retarder. The torque converter has automatic lock-up in all gears.

ZF 8 EP420

### HYDRAULIC SYSTEM

1 variable displacement piston pump for steering & tipping for cooling fan, brakes & auxiliaries

305 l / min @ 2100 rpm

#### Filtration

One return flow filter

#### Main safety valves pressures, tipping/steering circuit

280 / 210 bar

### TIRES

#### Standard

29.5 R25 Tubeless, two star radial

# SPECIAL FEATURES

## DA30/DA45

### Suspension

- Front: Semi-independent, self-leveling hydro-gas suspension.
- Rear: Free-swinging tandem housing.

### Articulation hinge and steering

- Articulation hinge with forward-mounted turning ring.
- Steering cylinders (two): Double-acting.
- The steering is approved according to ISO 5010.
- Max. steering angle : 45°.
- Ground-driven emergency steering pump.

### Driveline

- Full-time 6 x 6 drive with two transverse differentials and one longitudinal.
- Front axle transverse differential : Limited-slip diff lock with 45% locking ratio.
- Rear axle transverse differential : Limited-slip diff lock with 45% locking ratio.
- Inter-axle longitudinal differential :
  - Torque-proportioning differential, integrated in to the ZF transmission.
  - Torque distribution :
    - 1/3 to the front axle
    - 2/3 to the rear axle
    - 100 % lockable
- Tandem housing: Gear driven, free - swinging Provides equal drive to rear wheels and ensures the best possible ground contact – whatever the ground conditions.

### Brake system

- Dual circuit braking system acting on all six wheels.
- Approved according to ISO 3450.
- All hydraulic-operated brakes with enclosed oil-cooled wet multiple discs on four hubs (braking force distributed to two hubs by tandem gear wheels)
- Spring actuated hydraulic released parking brake, mounted on driveline shaft.
- Max. gradient, parking brake : 20 °
- Automatic transmission retarder as standard.

### Cab

- Approved to ROPS/FOPS standards (ISO 3471, ISO 3449).
- Low interior sound level : 71dB (ISO 6396).
- External sound level : 106db (ISO 6395).
- The cab is centrally located on rubber mountings.
- Hand and arm vibrations are less than 2.5 ms<sup>2</sup> (ISO 5349).
- Whole body vibration is less than 0.5 ms<sup>2</sup> (ISO 2631).
- Superior visibility – for safer operation.
- Superior operating controls location.
- Adjustable suspended operator seat.
- Adjustable steering column.
- Climate control – Heater and air conditioning.
- Tilting for service access.
- All-around hand rails.

# DIMENSIONS

## DA30

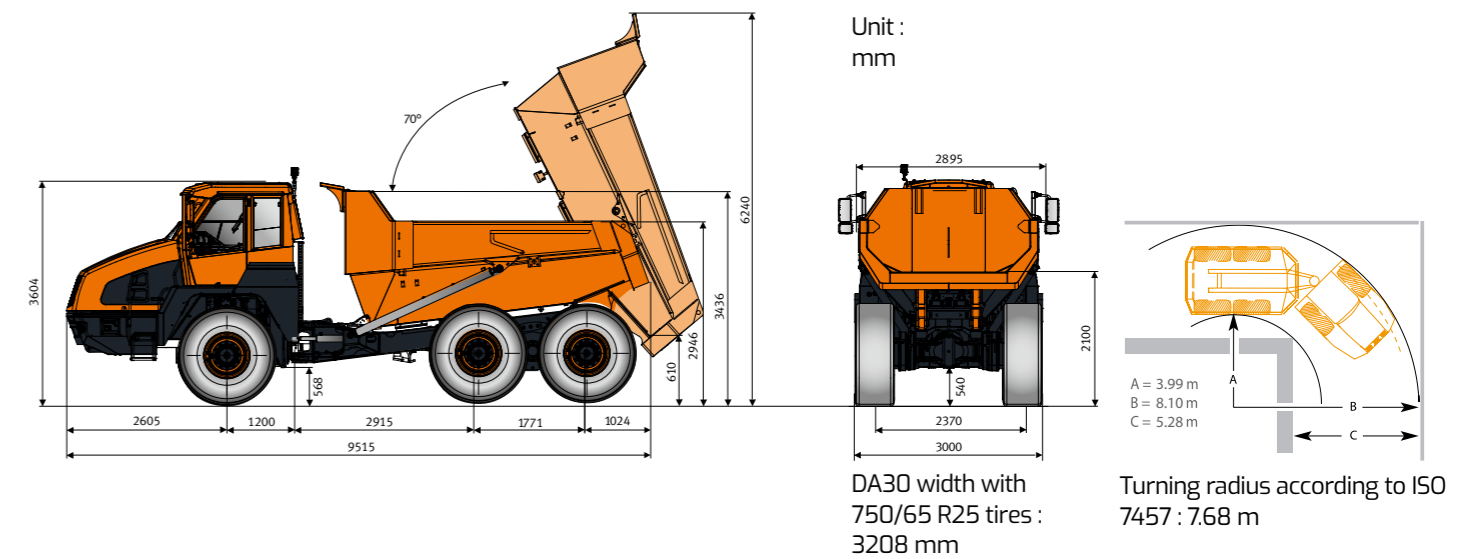

## DA45

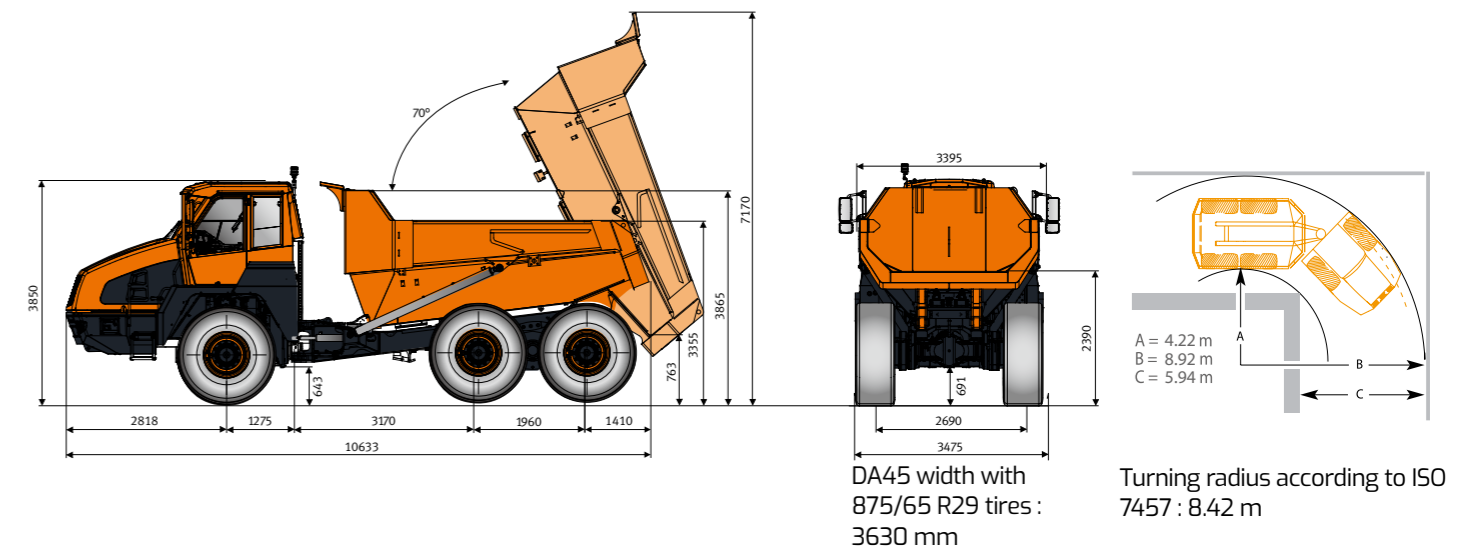

# STANDARD AND OPTIONAL EQUIPMENT

## STANDARD EQUIPMENT

### Engine

- Electronically controlled, direct injected, water-cooled, turbocharger, air-to-air intercooler
  - Preheater for easier cold starts
  - Exhaust brake

### Hydraulic System

- 1 variable displacement piston pump for steering & tipping
- One return flow filter

### Safety

- Gradient meter with anti-flip-over protection system
- Payload meter & cycle counter
- Wet disc brake
- Rear-view camera
- Hammer for emergency escape
- Hand rails on the fenders

### Other

- Transmission retarder brake
- Automatic lubrication system
- Mud flaps
- Towing hook, front and rear
- DEVELON Connect Telematic system
- Work light kit (rear and front)
- Load weighing system

### Cab & Interior

- Armrest at operator seat
- Headrest at operator seat
- Safety belt at operator and instructor seat
- Adjustable steering column
- All instrumentation in LCD display
- Cigarette lighter
- 12 V and USB charging point
- Retractable roller sunblind
- Tinted safety glass
- Sliding window (left & right side)
- Windshield wiper and washer
- Side mirrors
- Protection for rear window
- Emergency steering, ground-driven
- Radio/MP3 and Bluetooth
- Cab tilting system
- Emergency shutdown switch
- Anti-slip steps & platform
- Cool box compartment
- Storage room
- Electronic climate control
- High-comfort seat (vertical and longitudinal suspension)
- Heated operator seat

## OPTIONAL EQUIPMENT

### BODY

- Tailgate
- Body lining (400 HB)
- Side extension (200mm/250mm)
- Body heating kit

### Safety

- Seat belt green warning light
- Blue or orange flashing reverse light
- White noise alarm
- Air inlet Pre-Cleaner
- Protection for rear lights
- Wheel block

### Other

- Webasto heating system (heat up the cooling system)
- Fire extinguisher
- First aid kit
- Beacon
- Light bar
- Speed limitation
- Work light kit (rear and front) LED
- Tool kit
- Warning triangle
- Fast fill
- Tire pressure monitoring system (may not be available with all tires)
- Electrical diesel refueling pump
- Electrical adjustable heated mirror
- Electrical engine heater (230V)

### Tires options

- Quarry tires
- Earthmoving
- High flotation tires

Some of these options may be standard in some markets. Some of these options may not be available for certain markets. Please check with your local DEVELON dealer for more information about availability or to adapt your machine to your application needs.



Tail gate



LED lights

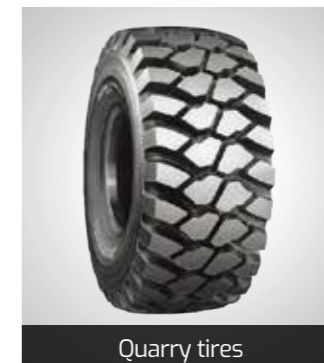

Quarry tires



High flotation tires

# We are **DEVELON**

We trace our roots to 1937 as one of Korea's first large scale machine plant. Throughout time we have consistently delivered exceptional products and solutions.

DEVELON is a bold name that reflects our core ambition to continue developing onwards and leaving behind a positive footprint in our world. Moving forward, we seek to be part of our customers and partners' endeavor to build a better world.

## Powered by **Innovation**



©2023 HD Hyundai Infracore. All rights reserved.  
**HDIPBE-01-2309**

Certain specification(s) are based on engineering calculations and are not actual measurements. Specification(s) are provided for comparison purposes only and are subject to change without notice. Specification(s) for your individual Develon equipment will vary based on normal variations in design, manufacturing, operating conditions, and other factors. Pictures of Develon units may show other than standard equipment

**[develon-ce.com](https://develon-ce.com)**

