

DOOSAN

Construction Equipment

High Reach Demolition

DX300 DM / DX340 DM / DX420 DM /
DX520 DM / DX700 DM



Demolition



DX 300 DM

DX 340 DM

DX 420 DM

DX 520 DM

DX 700 DM

KEY POINT

Customized Features

- Wide range of model choice
- Reinforced front linkage part
- Specialized cabin & Guard option
- Various selectable Attachments

Reliability

- Reliable and well protected hydraulic, electric and lubrication routings with simple, optimized layout

Comfort

- Operator orientated cabin design
- Simple and easy control panel

Fuel Efficiency

- Relief cut off
- Optimized lever control & Idle
- Engine & Pump Matching

Performance

- Powerful Doosan Engine for each model
- E-POS System(Electronic Power Optimizing System)

Maintenance

- Easy access to all maintenance components
- Intuitive maintenance data management

CUSTOMIZED FEATURES

High Reach demolition is mainly designed for more productive, cost-effective and safe tearing-down of buildings and other structures.

- Minimalized damage to surrounded building
- Secured operator's safety
- Maximized work efficiency though easy access to building by 3 pieces front parts.

WIDE RANGE OF MODEL CHOICE

Model	Front Type	Max. Pin Height (mm)	Max. Pin Reach (mm)	Boom Length (mm)	Mid Arm Length (mm)	End Arm Length (mm)	Additional Counter Weight (t)
DX300 DM	3-piece	18,095	10,315	9,100	2,600	5,000	3.6
DX340 DM	3-piece	21,215	12,065	10,500	2,600	6,500	4.0
DX420 DM	3-piece	22,890	13,435	11,700	2,600	7,000	4.5
DX520 DM	3-piece	26,180	13,840	13,700	2,700	8,000	5.0
DX700 DM	3-piece	30,080	17,660	15,400	2,700	9,800	5.5

OPTIMIZED FRONT LINKAGE PART

Durable front linkage

Designed highly reinforced box section and used high strength steel for enhancing strength

According with regulation

Designed to transport legally without disassembly for height.

Intermediates boom

can be inserted between base boom and extension boom for more working height.

Interchangeability (Optional)

Digging front package available

Boom can be divided for the machine to use standard excavation purpose.

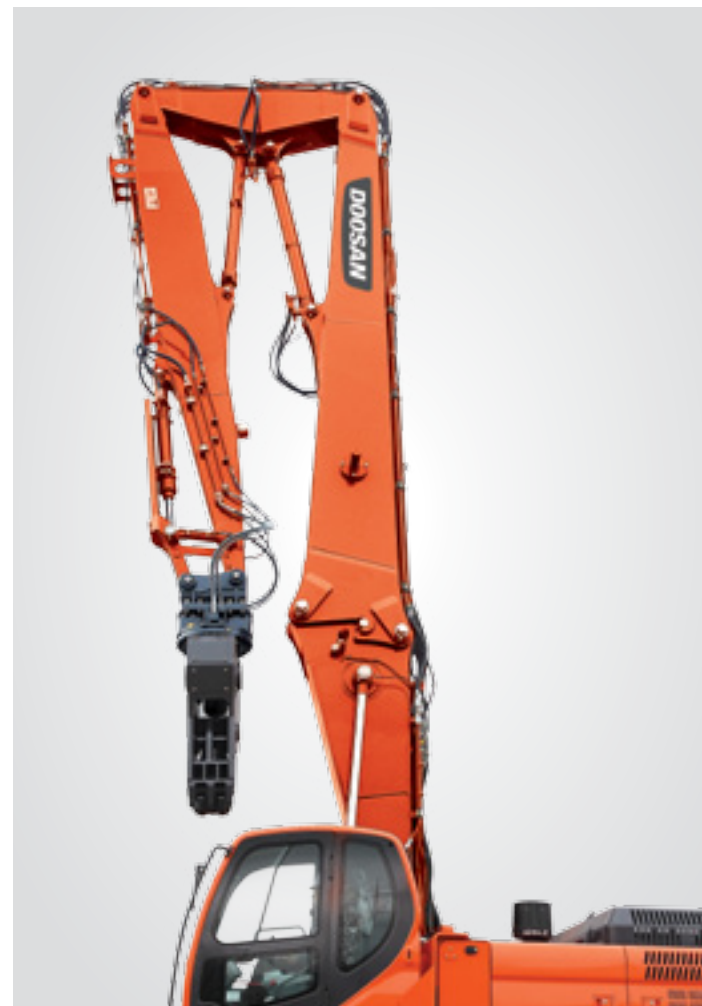

Water Spray System (Optional)

For controlling dust from demolishing, optional water spray system is available.

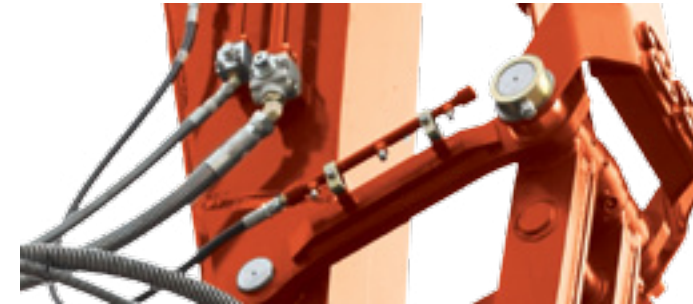

CCTV Camera on end arm & Monitor inside cabin (Optional)

Optional Camera located on end-arm support to secure visibility over 20m height.

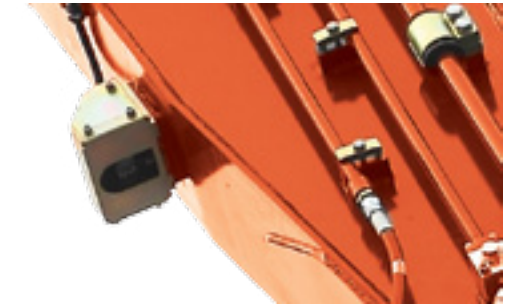

SPECIALIZED CABIN & GUARD OPTION

Tilting Cabin system

The cabin tilted to about 30° degrees upward by hydraulic cylinder offer to observe the top of the building and to control the attachment delicately.



Fall Objective Protection Structure (FOPS)

Operator protective guard (OPG) on the cabin to protect operator from falling objective from the top.



Lowering cab in emergency

When problem occurred during tilting position, it help the cab to change back into original position.

WORKING RANGE LIMITING SYSTEM

During the demolishing, if front angle drop down to certain angle could be occurred safety issue, it warns to operator to adjust working front angle.



CUSTOMIZED FEATURES

Doosan offer customized demolition attachment for each job application.

VARIOUS SELECTABLE ATTACHMENTS



Fixed Pulverizer

is designed for both primary demolition work and secondary concrete reduction. For secondary demolition, it is ideal for breaking out concrete from fixed structure, pulverizing concrete, separating different materials for recycling, and cutting reinforced rods and small steel profile.



Rotating Crusher

is designed for both primary demolition work and secondary concrete reduction. Especially for secondary demolition, it is ideal for breaking out concrete from fixed structure, pulverizing concrete, separating different materials for recycling, cutting reinforced rods and small steel profile, and working with high reach boom.



Multi-Processor

is designed for all demolition sites by inter-changing jaw sets mounted on a single base unit.



Multi-Grapple

is designed for selective demolition, sorting of recyclable material and loading of various materials.



Quick Coupler

is designed for increasing the versatility of excavators. DXQs will help you gain in productivity and efficiency with increased safety.

Attachments		Fixed Pulverizer		Rotating Crusher		Multi-Processor				Multi-Grapple		Quick Coupler	
Model		FP25	FP34	RC22	RC25	MP22-C	MP22-D	MP22-P	MP22-S	MG14	MG22	DXQ210S	DXQ300S
Operating Weight	kg	1,8980	2,745	1,780	2,300	2,040	2,050	2,210	1,880	1,050	1,423	335	510
Overall Length	mm	2,206	2,388	2,078	2,474	2,326	2,291	2,342	2,175	1,433	1,678	904	1031
Jaw width(Fixed/Moving jaw)	mm	470/346	532/370	438/350	470/346	1,438	1,368	1,508	1,083	900	1,000	-	-
Max. jaw opening	mm	889	1,061	732	925	903	797	893	503	1,273	1,536	-	-
Max. Operating Pressure	bar	350	350	350	350	350	350	350	350	-	-	350	350
Crushing/Closing Force(tip)	t	64	78	56	67	68	70	64	80	5	6	-	-
Cutter Blade Length	mm	360	360	240	360	237	355	237	348	(0.45m ³)	(0.75m ³)	-	-
Required oil flow	lpm	250-250	200-300	150-250	150-250	150-250	150-250	150-250	150-250	40-80	60-120	10-20	10-20
Speed control valve		●	●	●	●	●	●	●	●	-	-	-	-
bolting tooth		●	●	-	●	-	-	-	-	-	-	-	-
Applicable Carrier	DX300 DM	●	-	●	-	●	●	●	●	●		●	
	DX340 DM	●	-	●	-	●	●	●	●	●		●	
	DX420 DM	●	-	-	●	●	●	●	●	●		●	
	DX520 DM	●	-	-	●	●	●	●	●	●		●	
	DX700 DM	-	●	-	●	●	●	●	●		●		●

PERFORMANCE

The performance of the Doosan machine has a direct effect on its productivity. Its new improved engine and new e-EPOS controlled hydraulic system have combined to create an unbeatable hydraulic excavator, with a cost/performance ratio that makes the Doosan machine even more appealing.

Maximum performance by Doosan engine

Doosan engine perfectly harmonized with the hydraulic system and provides strong power. Mechanical engine providing high resistance to moisture, dust, and bad fuel quality.

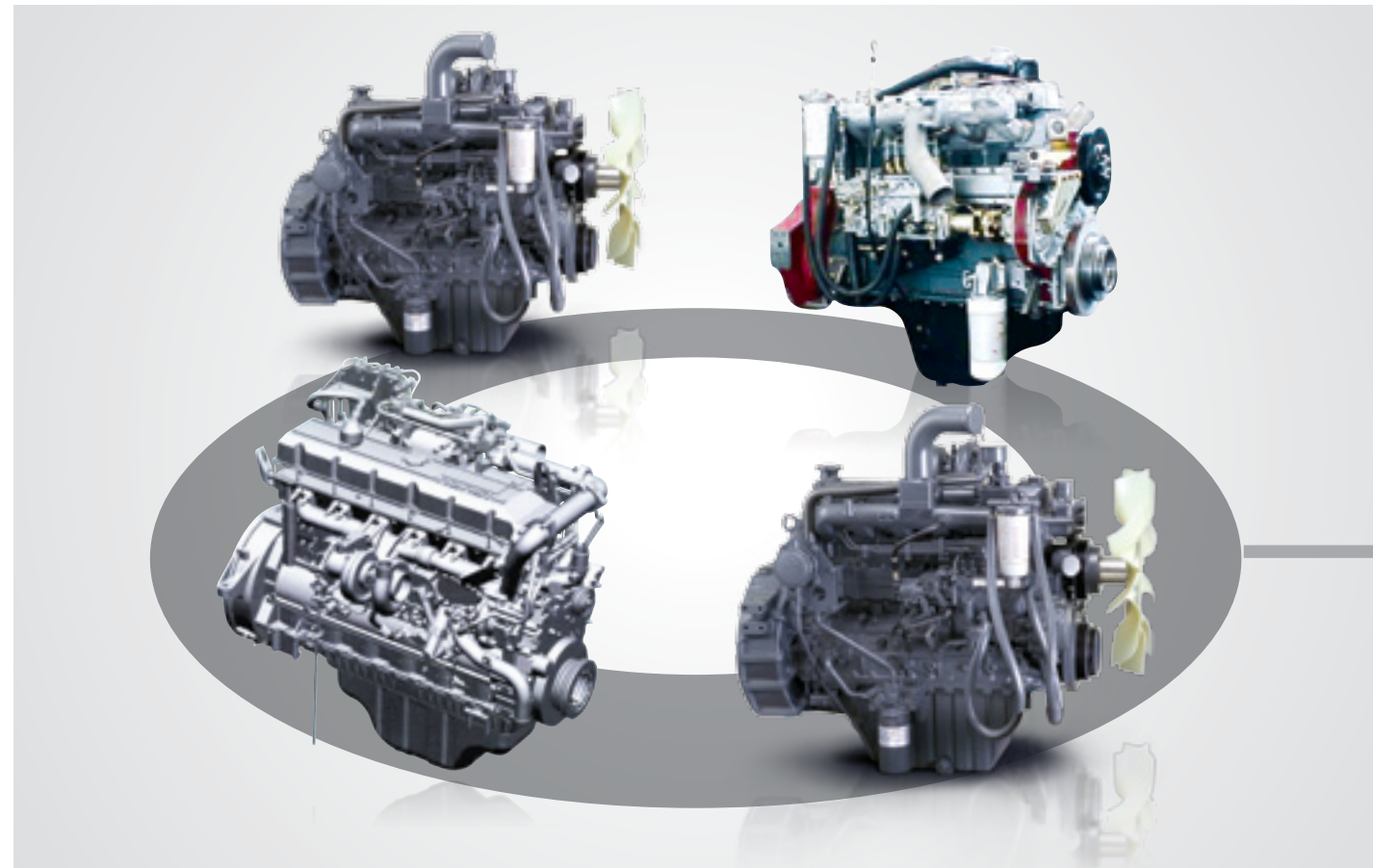

Smooth swing with increased swing torque

New motor swing reduction gear minimizes shocks during rotation while making increased swing torque.

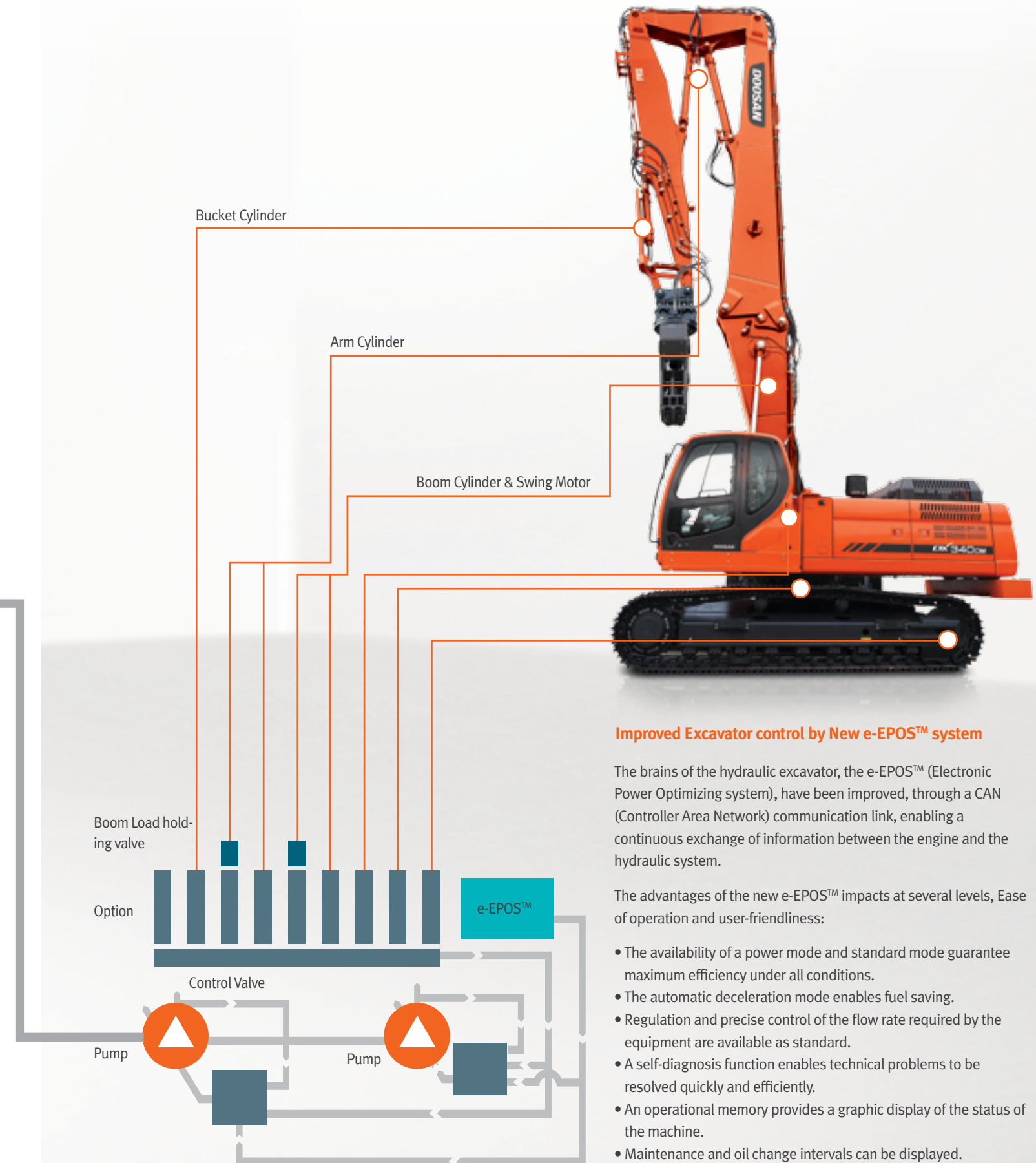
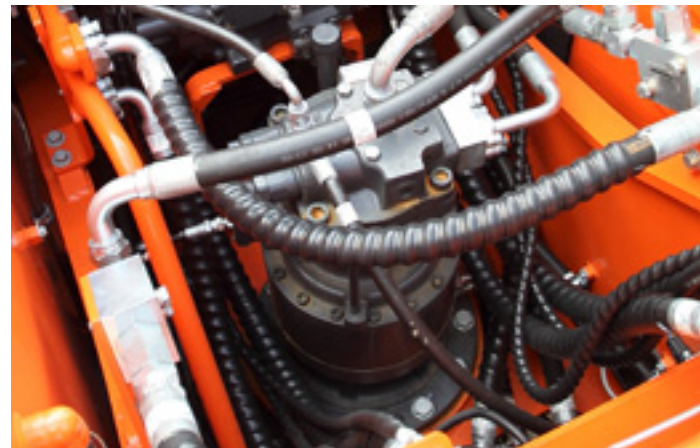

Improved Excavator control by New e-EPOS™ system

The brains of the hydraulic excavator, the e-EPOS™ (Electronic Power Optimizing system), have been improved, through a CAN (Controller Area Network) communication link, enabling a continuous exchange of information between the engine and the hydraulic system.

The advantages of the new e-EPOS™ impacts at several levels, Ease of operation and user-friendliness:

- The availability of a power mode and standard mode guarantee maximum efficiency under all conditions.
- The automatic deceleration mode enables fuel saving.
- Regulation and precise control of the flow rate required by the equipment are available as standard.
- A self-diagnosis function enables technical problems to be resolved quickly and efficiently.
- An operational memory provides a graphic display of the status of the machine.
- Maintenance and oil change intervals can be displayed.

FUEL EFFICIENCY



RELIEF CUTOFF

to prevent transfer of unnecessary flow

1. Typically, the pump tends to supply flow even when the maximum pressure on the system is reached due to severe working environments and large workloads.
2. Relief cutoff technology of Doosan prevent transfer of unnecessary flow to keep powerful working level at the maximum value while reducing consumption of fuel.

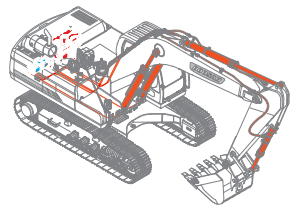

Relief cutoff

Relief cutoff technology saves 20~30% of fuel consumption in the heavy workload.



OPTIMIZED LEVER CONTROL

to prevent unnecessary fuel consumption

1. When operator takes break for rest with the joystick kept fixed, both of the engine and the pump are kept in standby mode with maximum rotation rate and hydraulic power. In such a case, unnecessary fuel consumption takes place.

Optimized Lever control

In auto idle, you can save 90% of fuel than in operation.



& AUTO IDLE

2. The auto idle technology effectively controls the engine, and prevents unnecessary fuel consumption while the engine is kept in standby mode. Further, the optimized lever control technology effectively controls the pump to keep power of the pump maximum and prevent fuel consumption while the system is kept shut down. When operating the joystick, rotation rate of the engine and maximum hydraulic power of the pump increase simultaneously for efficient consumption of fuel. The technologies of Doosan enable operation of the system with maximum power in time.



ENGINE & PUMP MATCHING

to reduce matching response time of the system

1. It is common that response time of the system (time for generating rated power from the minimum power) is slower than response speed of the pump. In such a case, the pump is kept in standby mode until the engine reaches the rated power to cause unnecessary fuel consumption. In addition, more fuel is supplied to the engine for matching the pump speed with the engine to result in more exhaust fumes.
2. Engine & pump matching, the new technology of Doosan, fully resolves these problems. Matching response time between pump and engine efficiently reduces unnecessary fuel consumption as well as exhaust fumes.

Engine & pump matching

Matching response time between pump and engine makes higher performance with reduced fuel consumption.

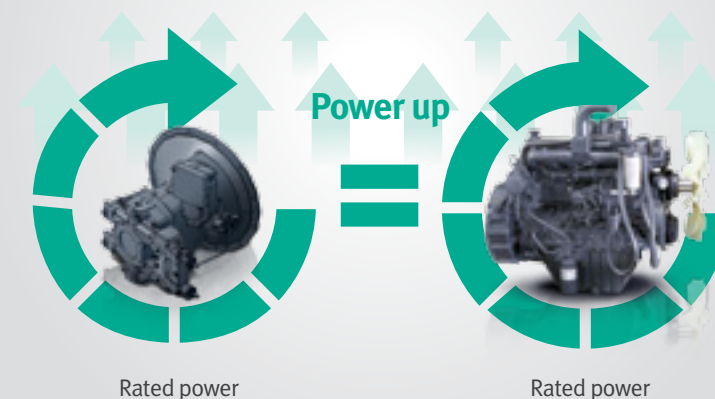

Doosan Efficient Dynamics Features

“NEW CONTROL LOGIC” for Better Fuel Efficiency

RELIABILITY

DOOSAN uses computer-assisted design techniques, highly durable materials and structures then test these under extreme conditions. Durability of materials and longevity of structures are our first priorities.

X-chassis

The X-chassis frame section has been designed using finite element and 3-dimensional computer simulation, to ensure greater durability and optimum structural integrity. The swing gear is solid and stable.



D-type Frame

The D-type frame and chassis frame add strength and minimize distortion due to shocks.

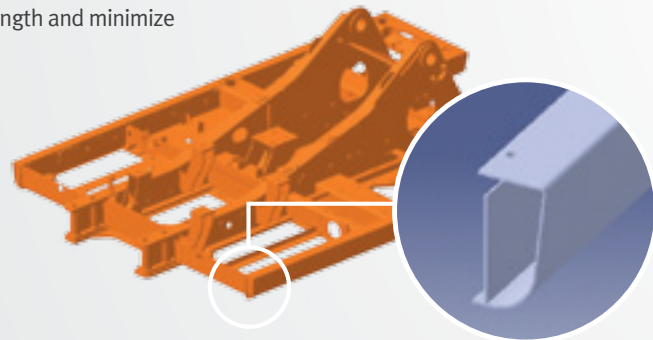

Tracks

The chain is composed of self-lubricating sealed links isolated from all external contamination. The tracks are locked by mechanically bolted pins.

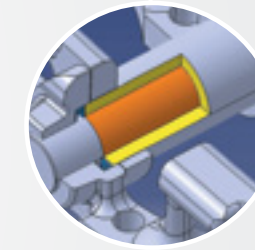

Integrated Track Spring and Idler

The track spring and the idler have been joined directly to achieve high durability and improved maintenance convenience.



Additional counter weight options

For keeping machine stability and performance, Doosan offer sand witch type or Bottom mounting type.



Bottom mounting type



Sand witch type

Polymer shim

A polymer shim is added to the bucket pivot to maintain precise control over the equipment.



Dry type of pre cleaner

Pre cleaner filters out impurities again for keeping steady machine performance.



COMFORT

The work rate of the hydraulic excavator is directly linked to the performance of its operator. DOOSAN designed a cabin by putting the operator at the center of the development goals. The result is significant ergonomic value that improves the efficiency and safety of the operator.

VISIBILITY

has been improved in all directions and the size of the cab has been increased.



Air suspension seat (Optional)

Equipped with various functions of adjustment forth and back and, and lumbar support, it reduces the vibration of equipment transmitted during work in an effective way. Also for considering winter working environment, Seat warmer functions equipped.

MP3/CD Player (Optional)



Audio Button



Audio Button has been positioned in a way that the driver can turn on/off the radio, control the volume, and select a channel conveniently.

Appropriate storage spaces show the attention given to the operator.



The high performance air conditioning provides an air flow which is adjusted and electronically controlled for the conditions. Five operating modes enable even the most demanding operator to be satisfied.

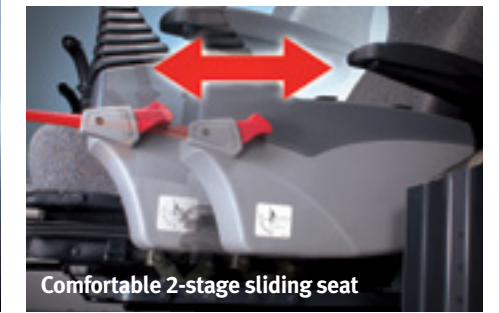

Comfortable 2-stage sliding seat

Rear Camera (Optional)



Control stand (Telescopic Function)

CONTROL OPTIONS

The hydraulic excavator's power, durability, ease of servicing and its precise control increase its effectiveness and life expectancy. DOOSAN offers an excellent return on investment.

Control lever

Very precise control of the equipment increases versatility, safety and facilitates tricky operations requiring great precision. Levelling operations and the movement of lifted loads in particular are made easier and safer.

The control levers have additional electrical buttons for controlling other additional equipment (for example, grabs, crushers, grippers, etc.)



Control panel

Correct positioning with clear controls makes the operator's task easier.



Cellular phone box



12V Power socket



Cigarette lighter

MAINTENANCE

Easy maintenance

Access to the various radiators and coolers is very easy, making cleaning easier. Access to the various parts of the engine is from the top and via side panels.

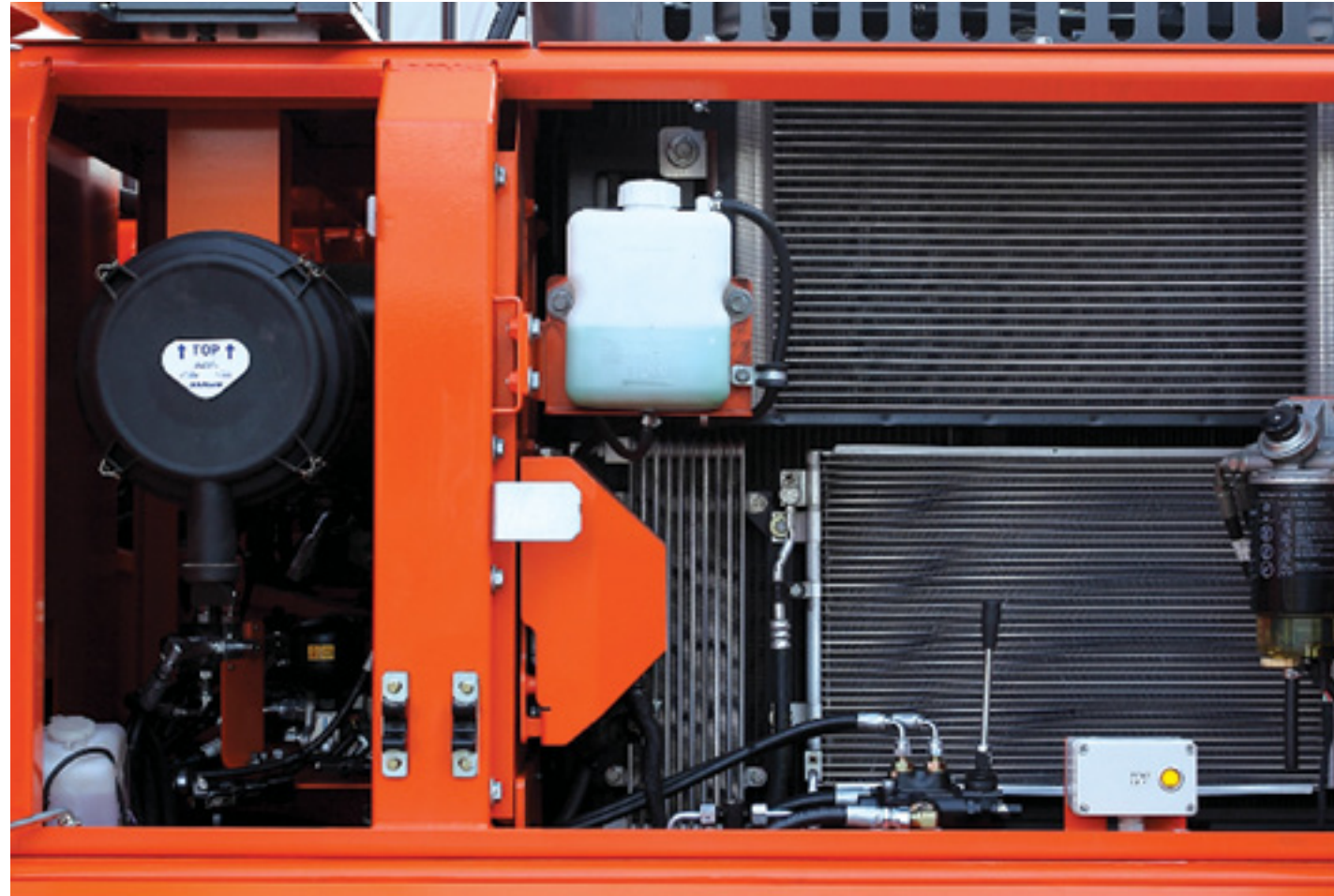

Fuel pre-filter

High efficiency fuel filtration is attained by the use of multiple filters, including a fuel pre-filter fitted with a water separator that removes most moisture from the fuel.



Air cleaner

The large capacity forced air cleaner removes over 99% of airborne particles, reducing the risk of engine contamination and making the cleaning and cartridge change intervals greater.



Remote greasing points

For comfortable maintenance, the boom, mid arm and end arm greasing points have been centralised. Remote & grouped greasing points on boom, mid arm and end arm.

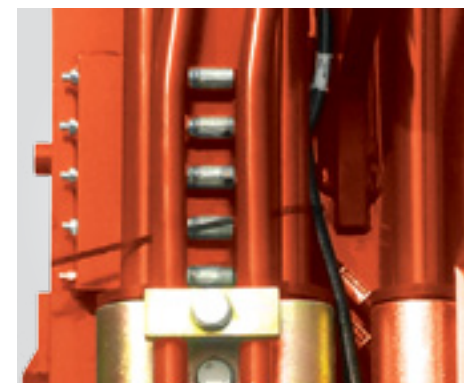

Hydraulic oil return filter

The protection of the hydraulic system is more effective, using glass fiber filter technology in the main oil return filter. This means that with more than 99.5% of foreign particles filtered out, the oil change interval is increased.



New battery box

- a. Cut-off switch easier to reach
- b. New spring to facilitate fixing
- c. New locking device



Convenient Fuse Box

The fuse box is conveniently located in a section of the storage compartment behind the operator's seat providing a clean environment and easy access.



PC monitoring

A PC monitoring function enables connection to the e-EPOS system. Thus, various parameters can be checked during maintenance, including pump pressures, engine rotation and engine speed. These can be stored and printed for analysis.



Larger anti-slip surface

High friction coefficient guarantees user's safety while maintaining main parts in wet condition.



TECHNICAL SPECIFICATION

DX300 DM

Engine

Model

Doosan DE08TIS

Type

Water-Cooled, Direct Injection

Number of cylinders

6

Rated Horse Power

200 PS @ 1900rpm (KS R1004)

147 kW (200 PS) @ 1,900 rpm (DIN 6271)

147 kW (197 HP) @ 1,900 rpm (SAE J1349)

Max torque

86 kgf.m @ 1,300 rpm

Piston displacement

8,071cc

Bore & stroke

Ø111 mm x 139 mm

Starting Motor

24 V x 6.0 kW

Batteries

12 V x 2/150 AH

Air cleaner

Double element and pre-filtered Turbo with auto dust evacuation.

Hydraulic System

The heart of the system is the e-EPOS (Electronic Power Optimizing System). It allows the efficiency of the system to be optimized for all working conditions and minimizes fuel consumption. The new e-EPOS is connected to the engine electronic control via a data transfer link to harmonize the operation of the engine and hydraulics.

- The hydraulic system enables independent or combined operations.
- Two travel speeds offer either increased torque or high speed tracking.
- Cross-sensing pump system for fuel savings.
- Auto deceleration system.
- Two operating modes, two power modes.
- Button control of flow in auxiliary equipment circuits.
- Computer-aided pump power control.

Main pumps

Tandem, Axial Piston

max flow : 2 x 247 ℓ /min

Displacement : 131 cc/rev

weight : 130 kg

Pilot pump

Gear pump - max flow : 28.5 ℓ /min

Pilot pump : 15 cc/rev

Relief valve pressure : 40 kgf/cm²

Main relief Pressure

Boom/Arm/Bucket

Working, Travel : 330 [+10~0] kg/cm²

Pressure up : 350 [+10~0] kg/cm²

Hydraulic Cylinders

The piston rods and cylinder bodies are made of high-strength steel. A shock absorbing mechanism is fitted in all cylinders to ensure shock-free operation and extend piston life.

Cylinders	Quantity	Bore diameter x Rod diameter x Stroke
Boom	2	140 x 95 x 1,440 mm
Mid Arm	1	150 x 105 x 1,755 mm
End Arm	1	140 x 100 x 1,450 mm
Bucket	1	120 x 80 x 1,060 mm

Undercarriage

Chassis are of very robust construction, all welded structures are designed to limit stresses. High-quality material used for durability. Lateral chassis welded and rigidly attached to the undercarriage. Track rollers lubricated for life, idlers and sprockets fitted with floating seals. Tracks shoes made of induction-hardened alloy with triple grousers. Heat-treated connecting pins. Hydraulic track adjuster with shock-absorbing tension mechanism.

Upper rollers(Standard shoe)

2

Lower rollers

9

Track shoes

48

Overall track length

4,940 mm

Swing Mechanism

High-torque, axial piston motor with planetary reduction gear bathed in oil. Swing circle is single row, shear type ball bearing with induction-hardened internal gear. Internal gear and pinion gear immersed in lubricant.

Swing speed

0 to 9.9 rpm

Max. swing torque

10,070 kgf.m (EFF.=0.84)

Drive

Each track is driven by an independent, high-torque, axial piston motor through planetary reduction gear. Two levers or foot pedal control provide smooth travel or counter-rotation upon demand.

Travel speed (low/high)

3.0 / 5.1 km/h (EFF.=98.5 / 97.7%)

Maximum traction force

25.2 / 13.7 ton (EFF.=76.5 / 71.2%)

Maximum grade

70 %

Refill Capacities

Fuel tank

500 ℓ

Cooling system (Radiator capacity)

35 ℓ

Engine oil

31.5 ℓ

Swing drive

6 ℓ

Final drive

2 x 7 ℓ

Hydraulic tank

280 ℓ

TECHNICAL SPECIFICATION

DX340 DM

Engine

Model

Doosan DE12TIS

Type

4-Cycle ATA Intercooler in-Line

Number of cylinders

6

Rated Horse Power

195 kW (265 PS) @ 1,800 rpm (DIN 6271)

185 kW (261 HP) @ 1,800 rpm (SAE J1349)

Max torque

112 kgf.m @ 1,400 rpm

Piston displacement

11,051 cc

Bore & stroke

Ø123 mm x 155 mm

Starting Motor

24 V x 6.0 kW

Batteries

12 V x 2/150 AH

Air cleaner

Double element

Hydraulic System

The heart of the system is the e-EPOS (Electronic Power Optimizing System). It allows the efficiency of the system to be optimized for all working conditions and minimizes fuel consumption. The new e-EPOS is connected to the engine electronic control via a data transfer link to harmonize the operation of the engine and hydraulics.

- The hydraulic system enables independent or combined operations.
- Two travel speeds offer either increased torque or high speed tracking.
- Cross-sensing pump system for fuel savings.
- Auto deceleration system.
- Two operating modes, two power modes.
- Button control of flow in auxiliary equipment circuits.
- Computer-aided pump power control.

Main pumps

Parallel, Bentaxis, Piston

max flow : 2 x 265 l /min

Displacement : 140 cc/rev

weight : 290 kg

Pilot pump

Gear pump - max flow : 22.5 l /min

Pilot pump : 11.86 cc/rev

Relief valve pressure : 40 kgf/cm²

Main relief Pressure

Boom/Arm/Bucket

Working, Travel : 330 [+10~0] kg/cm²

Pressure up : 350 [+10~0] kg/cm²

Hydraulic Cylinders

The piston rods and cylinder bodies are made of high-strength steel. A shock absorbing mechanism is fitted in all cylinders to ensure shock-free operation and extend piston life.

Cylinders	Quantity	Bore diameter x Rod diameter x Stroke
Boom	2	150 x 100 x 1,430 mm
Mid Arm	1	170 x 120 x 1,810 mm
End Arm	1	140 x 100 x 1,655 mm
Bucket	1	130 x 90 x 1,080 mm

Undercarriage

Chassis are of very robust construction, all welded structures are designed to limit stresses. High-quality material used for durability. Lateral chassis welded and rigidly attached to the undercarriage. Track rollers lubricated for life, idlers and sprockets fitted with floating seals. Tracks shoes made of induction-hardened alloy with triple grousers. Heat-treated connecting pins. Hydraulic track adjuster with shock-absorbing tension mechanism.

Upper rollers(Standard shoe)

2

Lower rollers

9

Track shoes

48

Overall track length

4,940 mm

Swing Mechanism

High-torque, axial piston motor with planetary reduction gear bathed in oil. Swing circle is single row, shear type ball bearing with induction-hardened internal gear. Internal gear and pinion gear immersed in lubricant.

Swing speed

0 to 8.9 rpm

Max. Swing Torque

11,660 kgf.m (EFF.=0.863)

Drive

Each track is driven by an independent, high-torque, axial piston motor through planetary reduction gear. Two levers or foot pedal control provide smooth travel or counter-rotation upon demand.

Travel speed (low/high)

3.1 / 4.7 km/h (EFF.=99.0 / 95.2%)

Maximum traction force

27.0 / 15.1 ton (EFF.=75.7 / 68.8%)

Maximum grade

70 %

Refill Capacities

Fuel tank

550 l

Cooling system (Radiator capacity)

34 l

Engine oil

39 l

Swing drive

6 l

Final drive

2 x 5.5 l

Hydraulic tank

380 l

TECHNICAL SPECIFICATION

DX420 DM

Engine

Model

DOOSAN DE12TIS
4-Cycle Air-To-Air Intercooler In-line
Water-Cooled, Direct Injection, Tier II

No. of cylinders

6

Rated horse power

218 kW (297 PS) @2,000 rpm (DIN 6271)
218 kW (293 HP) @2,000 rpm (SAE J1349)

Max. torque

127 kgf/m at 1,300 rpm

Idle (low - high)

975 [+/-50] - 2190 [+/-25] rpm

Piston displacement

11,051 cc

Bore & stroke

Ø123 mm x 155 mm

Starter

24 V / 7.0 kW

Batteries

2 x 12 V / 150 Ah

Air filter

Double element and pre-filtered Turbo with auto dust evacuation.

Hydraulic System

The brain of the excavator is the e-EPOS (Electronic Power Optimizing System). It allows the efficiency of the hydraulic system to be optimised for all working conditions and minimises fuel consumption. The e-EPOS is connected to the engine's electronic control unit (ECU) via a data transfer link to harmonise the operation of the engine and hydraulics.

- The hydraulic system enables independent or combined operations
- Two travel speeds offer either increased torque or high speed
- Cross-sensing pump system for fuel savings
- Auto deceleration system
- Three operating modes, three power modes
- Button control of flow in auxiliary hydraulic circuits
- Computer-aided pump flow control

Main pumps

Parallel, Bent-axis, Piston
Max. flow : 2 x 315 ℓ /min
Displacement : 162 cc/rev.
Weight : 180 kg

Pilot pump

Gear pump
Max. flow : 27.36 ℓ /min
Displacement : 11.0 cc /rev.
Relief valve pressure : 40 kgf/cm²

Maximum system pressure

Implement : 320 kgf/cm²
Travel : 320 kgf/cm²
Power Boost : 350 kgf/cm²
Pilot : 40 kgf/cm²

Hydraulic Cylinders

Piston rods and cylinder bodies of high-strength steel. Shock-absorbing mechanism fitted in all cylinders for shock-free operation and extended piston life.

Cylinders	Quantity	Bore diameter x Rod diameter x Stroke
Boom	2	165 x 115 x 1,460 mm
Mid Arm	1	170 x 120 x 1,810 mm
End Arm	1	140 x 100 x 1,655 mm
Bucket	1	130 x 90 x 1,080 mm

Undercarriage

Very robust construction of all chassis elements. All welded structures designed to limit stresses. High-quality, durable materials. Lateral chassis welded and rigidly attached to undercarriage. Track rollers lubricated for life. Idlers and sprockets fitted with floating seals. Track shoes made of induction-hardened alloy with triple grouser. Heat-treated connecting pins. Hydraulic track adjuster with shock-absorbing tension mechanism.

Upper rollers(Standard shoe)

2

Lower rollers

9

Track shoes

50

Overall track length

5,200 mm

Swing Mechanism

High-torque, axial piston motor with planetary reduction gear bathed in oil. Swing circle is single row, shear type ball bearing with induction-hardened internal gear. Internal gear and pinion gear immersed in lubricant.

Swing speed

0 to 9.1 rpm

Max. swing torque

13,510 kgf.m (EFF.=0.83)

Drive

Each track is driven by an independent, high-torque axial piston motor through a planetary reduction gearbox. Two levers or foot pedals guarantee smooth travel with counter-rotation on demand.

Travel speed (low/high)

3.3 / 5.5 km/h

Maximum traction force

37.74 / 18.05 ton (EFF.=85 / 75%)

Maximum grade

35° (70%)

Refill Capacities

Fuel tank

550 ℓ

Cooling system (Radiator Capacity)

29.5 ℓ

Engine oil

28 ℓ

Swing drive

7.9 ℓ

Final drive

2 x 6.3 ℓ

Hydraulic tank

390 ℓ

TECHNICAL SPECIFICATION

DX520 DM

Engine

Model

DOOSAN DE12TIS
4-Cycle Air-To-Air Intercooler In-line
Water-Cooled, Direct Injection, Tier II

No. of cylinders

6

Rated horse power

238 kW (323 PS) at 2,000 rpm (DIN 6271)
238 kW (318 HP) at 2,000 rpm (SAE J1349)

Max. torque

139 kgf/m (1363 Nm) at 1300 rpm

Piston displacement

11,051 cc

Bore & stroke

Ø123 mm x 155 mm

Starter

24 V / 6.6 kW

Batteries

2 x 12 V / 150 Ah

Air filter

Double element and pre-filtered Turbo with auto dust evacuation.

Hydraulic System

The brain of the excavator is the e-EPOS (Electronic Power Optimizing System). It allows the efficiency of the hydraulic system to be optimised for all working conditions and minimises fuel consumption. The e-EPOS is connected to the engine's electronic control unit (ECU) via a data transfer link to harmonise the operation of the engine and hydraulics.

- The hydraulic system enables independent or combined operations
- Two travel speeds offer either increased torque or high speed
- Cross-sensing pump system for fuel savings
- Auto deceleration system
- Three operating modes, three power modes
- Button control of flow in auxiliary hydraulic circuits
- Computer-aided pump flow control

Main pumps

Parallel, Bentaxis, Piston
Max. flow : 2 x 360 ℓ /min
Displacement : 186 cc/rev.
Weight : 195 kg

Pilot pump

Gear pump
Max. flow : 27.4 ℓ /min
Displacement : 11.0 cc/rev.
Relief valve pressure : 40 kgf/cm²

Maximum system pressure

Implement (boom/arm/bucket) :
Work, travel : 320 kg/cm² [+10~0]
Power : 350 kg/cm² [+10~0]

Hydraulic Cylinders

Piston rods and cylinder bodies of high-strength steel.
Shock-absorbing mechanism fitted in all cylinders for shock-free operation and extended piston life.

Cylinders	Quantity	Bore diameter x Rod diameter x Stroke
Boom	2	170 x 115 x 1,610 mm
Mid Arm	1	190 x 130 x 1,980 mm
End Arm	1	150 x 105 x 1,755 mm
Bucket	1	130 x 90 x 1,080 mm

Undercarriage

Very robust construction of all chassis elements. All welded structures designed to limit stresses. High-quality, durable materials. Lateral chassis welded and rigidly attached to undercarriage. Track rollers lubricated for life. Idlers and sprockets fitted with floating seals. Track shoes made of induction-hardened alloy with triple grouser. Heat-treated connecting pins. Hydraulic track adjuster with shock-absorbing tension mechanism.

Upper rollers(Standard shoe)

1 (Ø180 mm) + 2 (Ø200 mm)

Lower rollers

9 (Ø200 mm)

Track shoes

53

Overall track length

5,465 mm

Swing Mechanism

High-torque, axial piston motor with planetary reduction gear bathed in oil. Swing circle is single row, shear type ball bearing with induction-hardened internal gear. Internal gear and pinion gear immersed in lubricant.

Swing speed

0 to 9.2 rpm

Max. swing torque

15,500 kgf.m (EFF.=0.77)

Drive

Each track is driven by an independent, high-torque axial piston motor through a planetary reduction gearbox. Two levers or foot pedals guarantee smooth travel with counter-rotation on demand.

Travel speed (low/high)

3.2 / 5.6 km/h

Maximum traction force

37.6 / 18.9 ton (EFF.=85 / 75%)

Maximum grade

35° (70%)

Refill Capacities

Fuel tank

620 ℓ

Oil tank

390 ℓ

Engine oil

28 ℓ

Swing drive

2 x 5 ℓ

Final drive

2 x 10 ℓ

Hydraulic tank

390 ℓ

TECHNICAL SPECIFICATION

DX700 DM

Engine

Model

ISUZU MOTORS AH-6WG1XYSC-01

Type

Water-Cooled, Common Rail, Direct Injection

Number of cylinders

6

Rated Horse Power

345 kW (469 PS) @ 1,800 rpm (DIN 6271)

345 kW (463 HP) @ 1,800 rpm (SAE J1349)

Max torque

202 kgfm@ 1,500 rpm

Piston displacement

15,681 cc

Bore & stroke

Ø147 mm x 154 mm

Starting Motor

24 V x 7.0 kW

Batteries

12 V x 2/150 AH

Air cleaner

Double element with precleaner

Hydraulic System

The heart of the system is the e-EPOS (Electronic Power Optimizing System). It allows the efficiency of the system to be optimized for all working conditions and minimizes fuel consumption. The new e-EPOS is connected to the engine electronic control via a data transfer link to harmonize the operation of the engine and hydraulics.

- The hydraulic system enables independent or combined operations.
- Two travel speeds offer either increased torque or high speed tracking.
- Cross-sensing pump system for fuel savings.
- Auto deceleration system.
- Two operating modes, two power modes.
- Button control of flow in auxiliary equipment circuits.
- Computer-aided pump power control.

Main pumps

Parallel, Bentaxis, Piston

Max. flow : 2 x 436 ℓ /min

Displacement : 2 x 242 cc/rev.

Weight : 300 kg

Pilot pump

Gear pump

Max. flow : 27 ℓ /min

Displacement : 15 cc/rev.

Relief valve pressure : 39.8 kgf/cm²

Maximum system pressure

Implement (boom/arm/bucket) :

Work, travel : 320 kg/cm² [+10~0]

Power : 350 kg/cm² [+10~0]

Hydraulic Cylinders

Piston rods and cylinder bodies of high-strength steel.

Shock-absorbing mechanism fitted in all cylinders for shock-free operation and extended piston life.

Cylinders	Quantity	Bore diameter x Rod diameter x Stroke
Boom	2	190 x 125 x 1,795 mm
Mid Arm	1	190 x 130 x 1,980 mm
End Arm	1	180 x 120 x 1,820 mm
Bucket	1	140 x 90 x 1,150 mm

Undercarriage

Chassis are of very robust construction, all welded structures are designed to limit stresses. High-quality material used for durability. Lateral chassis welded and rigidly attached to the undercarriage. Track rollers lubricated for life, idlers and sprockets fitted with floating seals. Tracks shoes made of induction-hardened alloy with triple grousers. Heat-treated connecting pins. Hydraulic track adjuster with shock-absorbing tension mechanism

Upper rollers(Standard shoe)

3

Lower rollers

8

Track shoes

48

Track length

5,975 mm

Swing Mechanism

High-torque, axial piston motor with planetary reduction gear bathed in oil. Swing circle is single row, shear type ball bearing with induction-hardened internal gear. Internal gear and pinion gear immersed in lubricant.

Type

Axial Piston

Swing speed

7.1 rpm (EFF.=0.98)

MAX. SWING TORQUE

22,070 kgf.m (EFF.=0.77)

Drive

Each track is driven by an independent, high-torque, axial piston motor through planetary reduction gear. Two levers or foot pedal control provide smooth travel or counter-rotation upon demand.

Travel speed (low/high)

2.8/4.6 km/h (EFF.=97%)

Maximum traction force

48.9/42.4 ton (EFF.=76.4/65.4%)

Maximum grade

70 %

Refill Capacities

Fuel tank

900 ℓ (Diesel)

Cooling system (Radiator capacity)

69 ℓ (Water)

Engine oil

52 ℓ

Swing Device

2 x 6 ℓ

Travel Device

2 x 20 ℓ

Lever

350 ℓ

Oil Tank

Lever 350 ℓ

System (Tank full) 790 ℓ

DIMENSIONS & WORKING RANGE

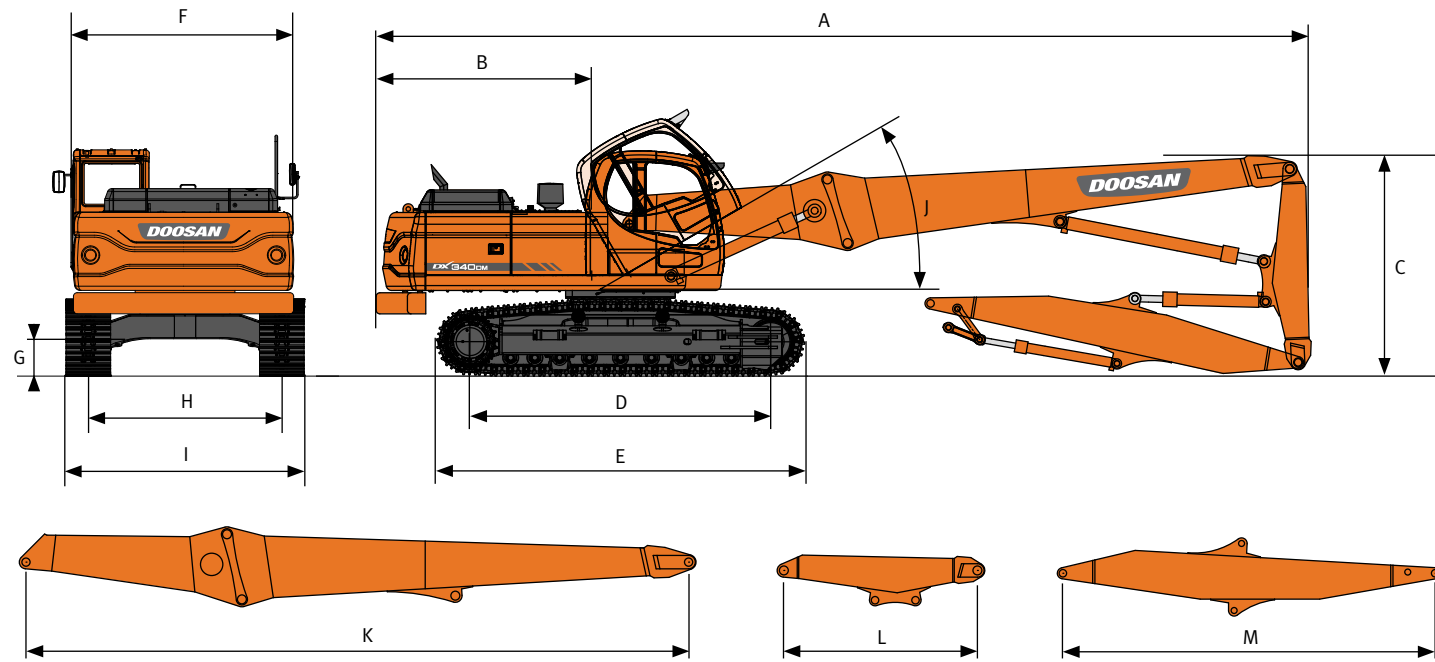

Transport Dimension

Dimension	Unit	DX300 DM	DX340 DM	DX420 DM	DX520 DM	DX700 DM
A Shipping Length	mm	12,940	14,650	15,830	18,100	20,250
B Tail Swing Radius	mm	3,200	3,500	3,660	3,700	4,010
C Shipping Height	mm	3,370	3,450	3,450	3,720	3,750
D Tumbler Distance	mm	4,040	4,050	4,250	4,470	4,730
E Track Length	mm	4,940	4,940	5,200	5,465	5,975
F House Width	mm	2,960	2,990	2,990	2,990	3,410
G Ground Clearance	mm	500	510	540	770	870
H Track Gauge	mm	2,600	2,680	2,750	2,740 / 3,300*	2,910 / 3,350*
I Shipping Width	mm	3,200	3,280	3,350	3,340 / 3,900*	3,560 / 4,000*
J Cabin Tilting Angle	degree	30°	30°	30°	30°	30°
K Boom Length	mm	9,100	10,500	11,700	13,700	15,400
L Mid Arm Length	mm	2,600	2,600	2,600	2,700	2,700
M End Arm Length	mm	5,000	6,500	7,000	8,000	9,800

[Note]* : Retracted / Extended

Weight of Main Parts

Parts	Unit	DX300 DM	DX340 DM	DX420 DM	DX520 DM	DX700 DM
Additional CWT	kg	3,600	4,000	4,500	2,500	5,500
Cabin	kg	1,300	1,300	1,300	1,300	1,300
Base Boom	kg	1,700	2,150	2,500	2,620	3,000
Extension Boom	kg	2,500	3,200	4,000	4,500	5,800
Mid Arm	kg	1,000	1,050	1,100	1,200	1,500
End Arm	kg	1,500	1,800	1,850	1,900	2,980
Etc. (Cylinder & Piping)	kg	1,470	2,400	3,050	3,955	4,270
Total	kg	13,070	15,900	18,300	17,975	24,350

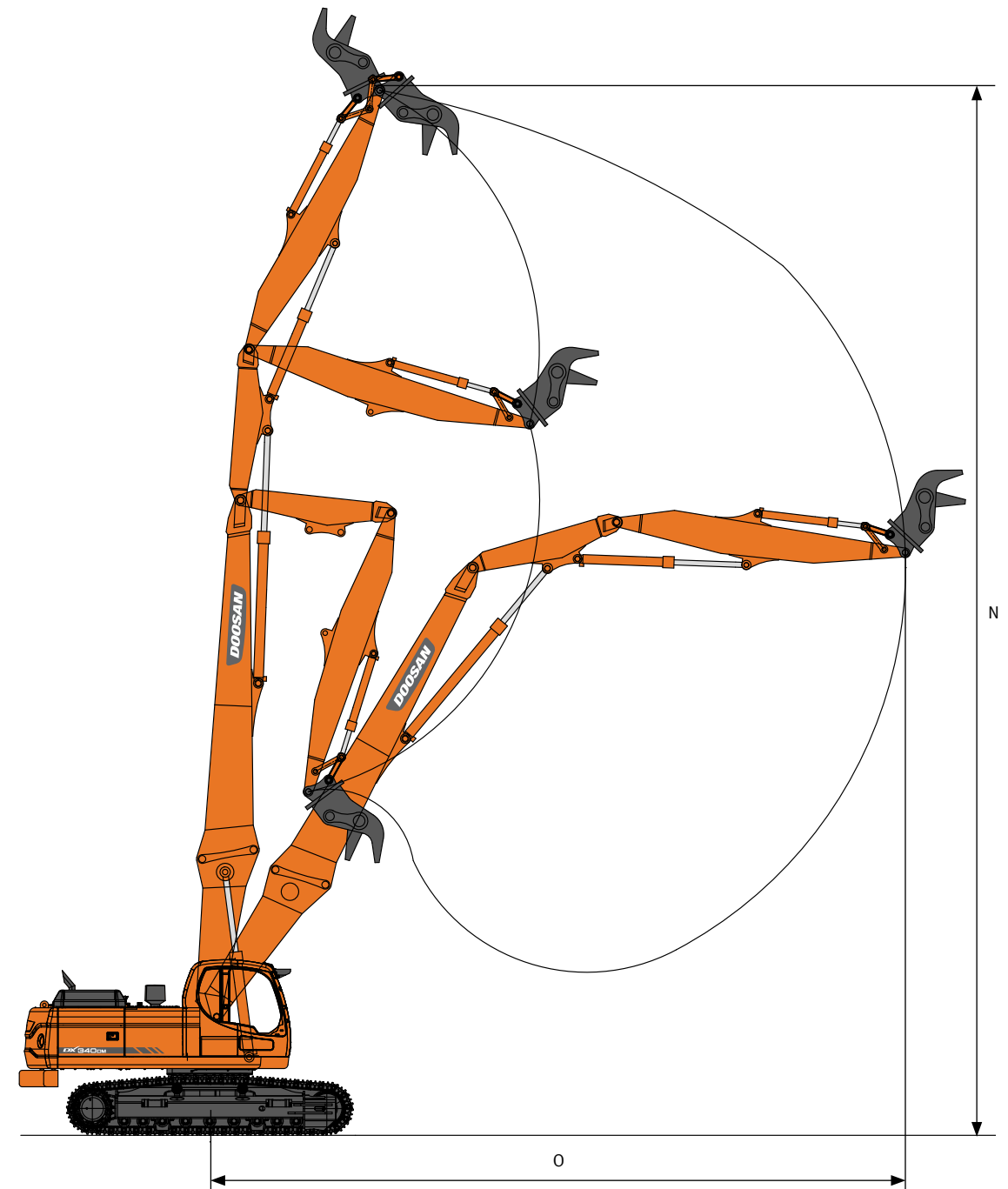

Working Range

Dimension	Unit	DX300 DM	DX340 DM	DX420 DM	DX520 DM	DX700 DM
N Max. Pin Height	mm	18,095	21,215	22,890	26,180	30,080
O Max. Pin Reach	mm	10,315	12,065	13,435	13,840	17,660

STANDARD AND OPTIONAL EQUIPMENT

Standard Equipment

Front and counterweight parts

- Base boom, extension boom, mid arm and end arm
- Arm and bucket cylinders
- Bucket linkage assembly
- Hydraulic piping for arm, bucket, attachment and rotating functions
- Additional counterweight

Hydraulic system

- Boom and arm flow regeneration
- Boom and arm holding valves
- Swing anti-rebound valves
- One-touch power boost
- Piping for special attachment
 - Attachment open/close
 - Rotating

Cabin & Interior

- Viscous cab mounts
- All weather sound suppressed type cab
- Air conditioner & Heater
- Adjustable suspension seat with head rest and adjustable arm rest
- Pull-up type front window and removable lower front window
- Room light
- Intermittent windshield wiper
- Cigarette lighter and ashtray
- Cup holder
- Hot & Cool box
- 7" LCD color monitor panel
- E/G RPM control dial
- AM/FM radio
- Remote radio ON/OFF switch
- 12V spare powers socket
- Serial communication port for laptop PC interface
- Joystick lever with 3 switches
- Sun visor
- Sun roof

Safety

- Large handrails and step
- Convex metal anti-slip plates
- Seat belt
- Hydraulic safety lock lever
- Safety glass
- Hammer for emergency escape
- Right and left rear view mirrors
- Travel alarm
- Battery protector cover
- Battery cut off switch
- Lock vlave
- Boom angle warning device

Others

- Double element air cleaner
- Water separator
- Fuel filter
- Dust screen for radiator/oil cooler
- Engine overheat prevention system
- Engine restart prevention system
- Self-diagnostic system
- Alternator(24V, 50 amps)
- Electric horn
- Halogen working lights(frame mounted 1, boom mounted 2)
- Hydraulic track adjuster
- Track guards
- Greased and sealed track link
- Hydraulic oil tank air breather filter

Optional Equipment

Front parts and hydraulic system

- Digging front (boom, arm and bucket) and cradle
- Piping for digging front
- Quick coupler piping
- Drain piping for attachment
- Water spray system

Cabin & Interior

- Cabin with hydraulic tilting system
- OPG(Operator protective guard) on cabin
- Air suspension seat
- MP3/CD player
- Cassette player
- Rain shield
- High mount seat
- Rear Camera

Safety

- ROPS cabin
- Overload warning device
- Cabin Top/Front guard(ISO 10262, FOGS standard)
- Travel & swing alarm
- Rotation beacon

Others

- 700 mm / 800 mm / 900 mm shoe
- Lower wiper
- Fuel heater
- 80A alternator
- Fuel filler pump
- Additional working lights
 - 4-front / 2-rear on cabin
 - 2-front on cabin
 - 1 on counterweight
- Camera on end arm & Monitor inside cabin

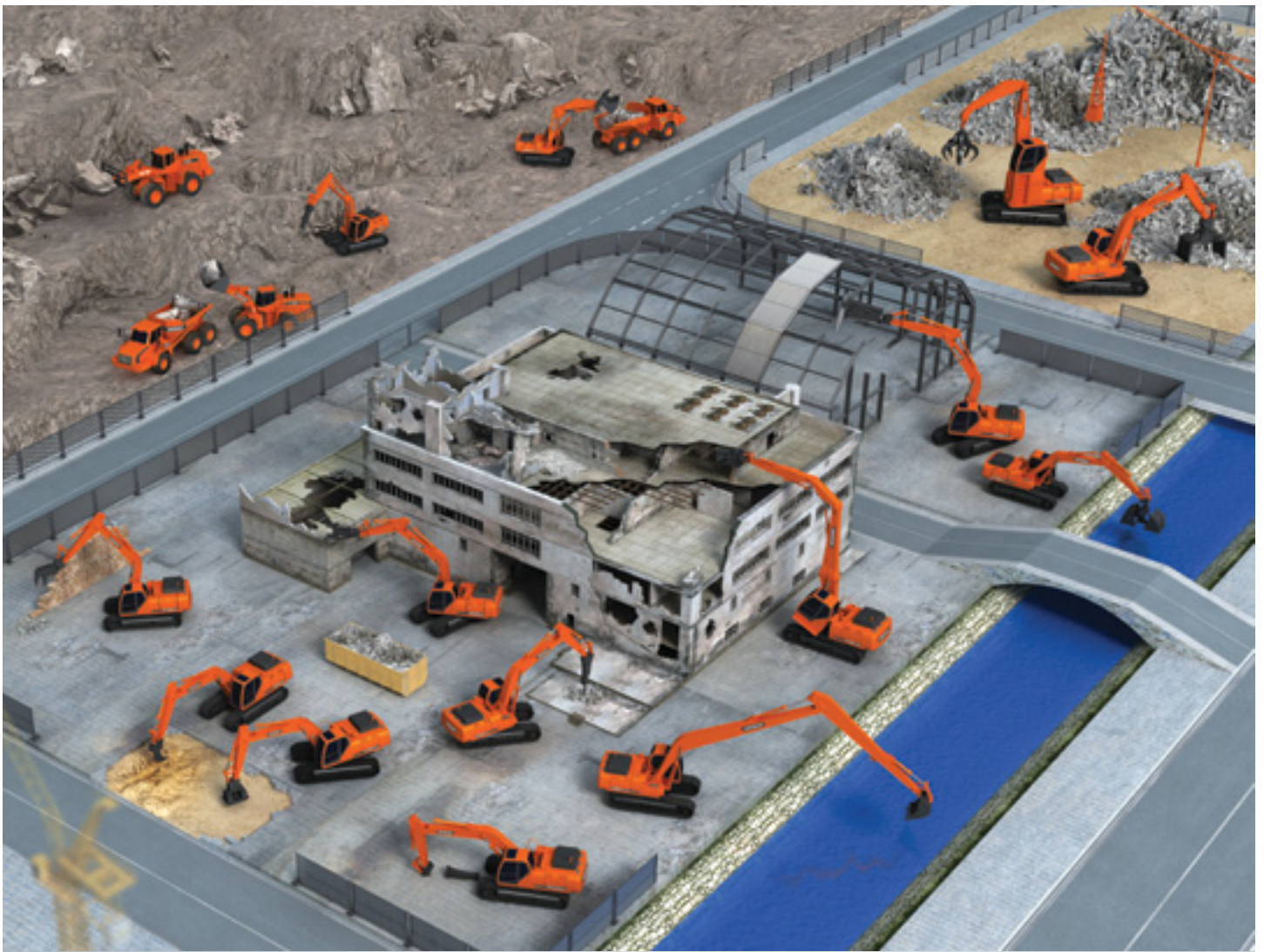

EXCAVATOR



WHEEL LOADER

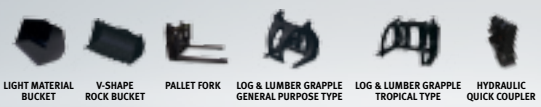

DL series



DISD series



Doosan Infracore Korea Office (HQ)
 27/F, 275, Jangchungdan-ro, Jung-gu, Seoul, Korea
 Tel : 82 2 3398 8114

www.doosaninfracore.com/ce/