

ZAPI intelligent display provides vital information such as speed and battery discharge status and is used to customize performance parameters

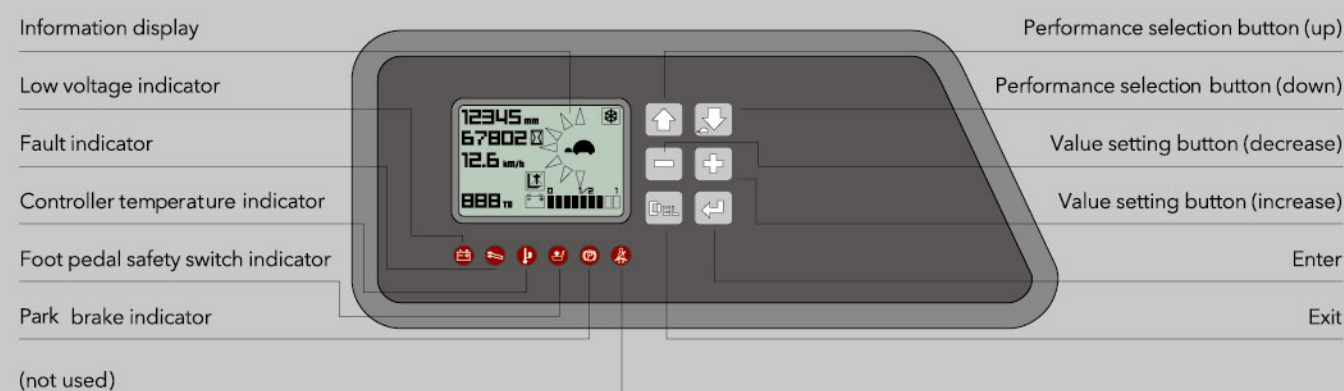

ZAPI intelligent display for GB2R model

Standard configuration

- 36V electric system
- All AC motors with ZAPI controls
- 218" (5330mm) 3-stage full free lift mast
- Integral pantograph with tilt and sideshift
- Standard forks
- Load backrest
- Polyurethane tires
- Electromagnetic proportional valve
- Battery rollers
- Overhead guard
- LED combined display
- Front work light
- LED warning light
- Automatic steering slow down
- Electromagnetic, regenrative service brake
- Automatic park brake
- Low noise gear pump
- DC/DC converter

Optional

- 48V electric system
- Additional mast heights - 198-300" (5025-7620mm)
- Lifting height pre-selector
- Monitoring system
- Additional batteries including Hoppecker and FAAM
- Battery charger
- Custom paint
- Additional operator protection guard
- Battery loading and unloading cart

ANHUI HELI CO., LTD.
 ADD:NO 668 Fangxing Street,Economical Development
 Zone,Hefei,P.R.China
 TEL :86 551)63639458
 FAX :86 551)63639966
 WEBSITE: http://www.chliforklift.com
 EMAIL: chl@chliforklift.com

AUTHORIZED DEALER

* Details of specifications and equipment are based on information available at the time of printing and may change without notice.



CQD16-18X1
3500-4000 lbs [1.6-1.8t]

36/48V Reach Truck
G Series AC Electric

CQD16-18X1

36/48V Reach Truck
G Series AC Electric



Multi-function joystick handle and proportional controls produce are easy and intuitive to use



Operator compartment provides comfort and efficient operation



Great visibility for improved operation and safety

Operator comfort

- > Rear padding and armrest help reduce fatigue
- > Multifunction control is ergonomically designed and easy to use
- > All controls are within easy reach to help reduce body strain
- > Compartment floor is angled and spring suspended to reduce leg and back strain

Improved operator's view

- > Large, rounded overhead guard is stylish and combined with strategically angled bars provides maximum visibility
- > Newly designed, wide view mast with special chains enlarges the operator's view looking forward

Safety

- > Side stance improves operator's visibility both forward and backward
- > Automatic park brake applies when operator leaves the compartment or shuts forklift off
- > Programmable automatic deceleration in turns adds to safe operation
- > Warning lights and OPS system come standard

Working efficiency

- > Small turning radius makes steering flexible and easy
- > With ZAPI control and AC powered motors, drive and lift systems can be programmed for maximum efficiency and performance
- > The large battery capacity for longer single shift work operation
- > With standard battery roller and side removal, battery change is quick and easy

Energy efficiency

- > With an optimized hydraulic system, truck is more energy efficient
- > All LED lights saves 80% of lighting energy
- > Regenerative motor braking recycles more energy during braking cycles
- > Programmable speed and acceleration settings can be set for maximum energy efficiency

Serviceability

- > Side door gives easy access to drive motor and gearbox
- > Chassis components are well laid-out and can be accessed with removable top and front covers





Wide view mast and pantograph

- Comes standard with side shift, tilt and reach functions
- Wide-view mast and pantograph maximize operator's view
- Lift cylinders have end stroke cushions for smooth stopping
- ZAPI controller provides in transit buffers to ensure smooth lifting and lowering throughout the lifting cycle
- The controller also provides in-transit and end stroke buffer for the reach function

Overhead guard

- Overhead guard attaches directly to mast to eliminate front guard legs
- Optimally designed for maximum operator visibility
- Standard with left side guard leg for added strength
- Optional operator compartment guard leg for added safety

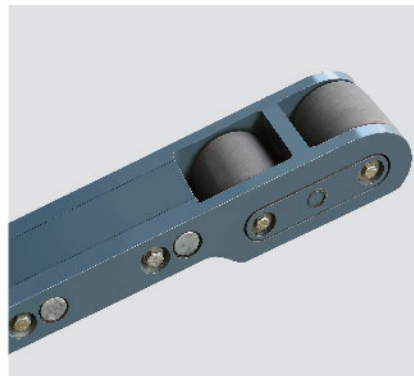

Bolt on outrigger boxes and easy change load wheels



Easy access to drive components

Heli's New Reach Trucks

Designed for productivity



ZAPI smart display & multi-function joystick

Designed for safety



Standard lights, mesh finger guard & overhead guard with leg

Designed for serviceability



Easy to remove covers to access all electric and hydraulic components

CQD16-18X1 36/48V Reach Truck G Series AC Electric

Manufacturer's Data and Design Characteristics									
Characteristics									
1.01	Manufacturer								
1.02	Model								
1.03	Configuration number								
1.04	Load capacity	Q	lb	kg	3500	1600	4000	1800	
1.05	Load center	C	in	mm	24	600	24	600	
1.06	Power mode								
1.07	Operator Type								
1.08	Wheel base	L2	in	mm	55	1407	57	1457	
1.09	Voltage		v	v	36	36	36	36	
Tire									
2.01	Tire type				Polyurethane	Polyurethane	Polyurethane	Polyurethane	
2.02	Wheel number,drive/load/caster (X=drive wheel)				1x/4/2	1x/4/2	1x/4/2	1x/4/2	
2.03	Wheel size,load (diameter x length)		in	mm	Φ5×3.7	Φ127×95	Φ5×3.7	Φ127×95	
2.04	Wheel size,drive (diameter x length)		in	mm	Φ13×5.5	Φ330×140	Φ13×5.5	Φ330×140	
2.05	Wheel size,caster (diameter x length)		in	mm	Φ7.4×3	Φ178×76	Φ7.4×3	Φ178×76	
Dimensions									
3.01	Lift height (with standard mast)	H	in	mm	210	5330	210	5330	
3.02	Mast height,lowered	H1	in	mm	99	2526	99	2526	
3.03	Free lift	H8	in	mm	59	1490	59	1490	
3.04	Fork size (thickness x width x length)		in	mm	1.4×3.9×36.2	35×100×920	1.4×3.9×36.2	35×100×920	
3.05	Fork adjusting width	W4	in	mm	9.6~28.5	244~724	9.6~28.5	244~724	
3.06	Tilt (forward/backward)		deg	deg	3°/4°	3°/4°	3°/4°	3°/4°	
3.07	Fork sideshifting		in	mm	±2	±50	±2	±50	
3.08	Truck body length(fork excluded)	L	in	mm	71	1815	73	1865	
3.09	Truck body width	W	in	mm	43	1090	43	1090	
3.10	Straddle leg, inside width	W2	in	mm	33~51	845~1300	33~51	845~1300	
3.11	Straddle leg, outside width	W1	in	mm	47~59	1192~1492	47~59	1192~1492	
3.12	Fork carriage width	W3	in	mm	33	842	33	842	
3.13	Reach distance	S	in	mm	24	600	24	600	
3.14	Height of overhead guard	H7	in	mm	91	2320	91	2320	
3.15	Battery bottom clearance	H4	in	mm	7	180	7	180	
3.16	Straddle clearance	H5	in	mm	2	50	2	50	
3.17	Straddle height	H9	in	mm	5	130	5	130	
3.18	Step height	H6	in	mm	10	250	10	250	
3.19	Minimum turning radius	Wa	in	mm	67	1695	69	1745	
3.20	Rear overhang (drive wheel center to rear of frame)	L1	in	mm	10	252	10	252	
3.21	Front fork face to rear of frame distance	L4	in	mm	55	1396	55	1396	
3.22	Aisle width with pallet 48"Lx48"W (1200x1200)	Ast	in	mm	109	2771	111	2812	
3.23	Aisle width with pallet 40"Lx40"W (1000x1000)	Ast	in	mm	100	2550	102	2591	
Performance									
4.01	Travel speed loaded/unloaded		mph	km/h	6.5/7.3	10.5/11.8	6.5/7.3	10.5/11.8	
4.02	Lift speed loaded/unloaded		fpm	mm/s	65/100	330/510	65/100	330/510	
4.03	Lowering speed loaded/unloaded		fpm	mm/s	98/98	500/500	98/98	500/500	
4.04	Reach speed loaded/unloaded		fpm	mm/s	22/30	110/150	22/30	110/150	
4.05	Max.gadeability loaded/unloaded - 5 minute rating		%	%	10/15	10/15	10/15	10/15	
Weight									
5.01	Total weight(without battery)		lb	kg	5400	2450	5644	2560	
5.02	Axle loading, no load (fomt/rear)		lb	kg	2844/4321	1290/1960	2954/4762	1340/2160	
5.03	Axle loading, loaded (fomt/rear)		lb	kg	7165/3527	3250/1600	7606/3968	3450/1800	
Battery									
6.01	Capacity at 6 hr.Discharge rate		kwh	Ah	27.2	775	32.6	930	
6.02	Maxmum battery weight		kwh	Ah	2100	953	2350	1066	
6.03	Minimum battery weight		lb	kg	1600	726	1850	839	
6.04	Battery compartment dimension		in	mm	39.5×15.2×31.8	1005×388×810	39.5×16.8×31.8	1005×428×810	
Motor and controller									
7.01	Driving motor power		HP	kw	9.4	7	9.4	7	
7.02	Lifting motor power		HP	kw	20.1	15	20.1	15	
7.03	Steering motor power		HP	kw	0.8	0.6	0.8	0.6	
7.04	Type of driving control								MOSFET/AC
7.05	Type of lifting control								MOSFET/AC
7.06	Type of steering control								MOSFET/AC
7.07	Transmission box								HELI special
7.08	Service brake								Electric
7.09	Hydraulic system working pressure		PSI	Mpa	3050	21	3050	21	

NOTE: For detailed information about battery,please contact your authorized HELI dealer. These are "Zero Clearance" aisles in the table and require an additional 150mm or more to be added to provide for easier maneuvering.

WIDE VIEW FULL FREE 3-STAGE MAST

Mast model	Fork Height h3 (in)(mm)		Free lifting height h3 (in)(mm)		Mast height h1 (in)(mm)		Load Capacity at 24" Load Center (lb) (kg)		Service Weight (lb) (kg)											
	CQD16X1	CQD18X1	CQD16X1	CQD18X1	CQD16X1	CQD18X1	CQD16X1	CQD18X1	CQD16X1	CQD18X1										
ZSM502	198	5025	198	5025	55	1390	95	2413	95	2413	3527	1600	3968	1800	7374	3345	7672	3480		
ZSM533	210	5330	210	5330	59	1490	59	1490	99	2526	99	2526	3527	1600	3858	1750	7419	3365	7716	3500
ZSM610	240	6095	240	6095	69	1745	69	1745	109	2781	109	2781	3527	1600	3858	1750	7573	3435	7871	3570
ZSM685	270	6855	270	6855	79	2000	79	2000	120	3036	120	3036	2425	1100	2866	1300	7683	3485	7981	3620
ZSM762	300	7620	300	7620	90	2285	90	2285	131	3321	131	3321	2094	950	2425	1100	7837	3555	8135	3690

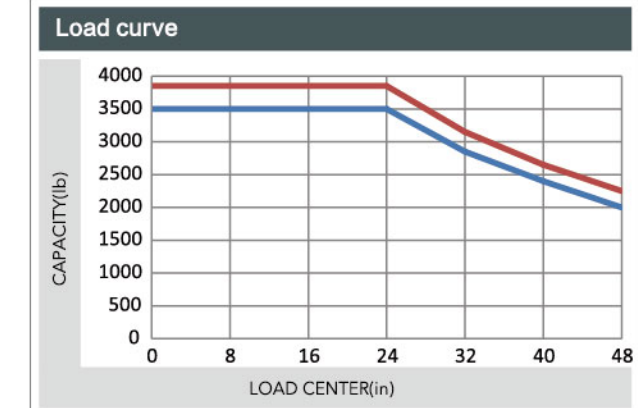
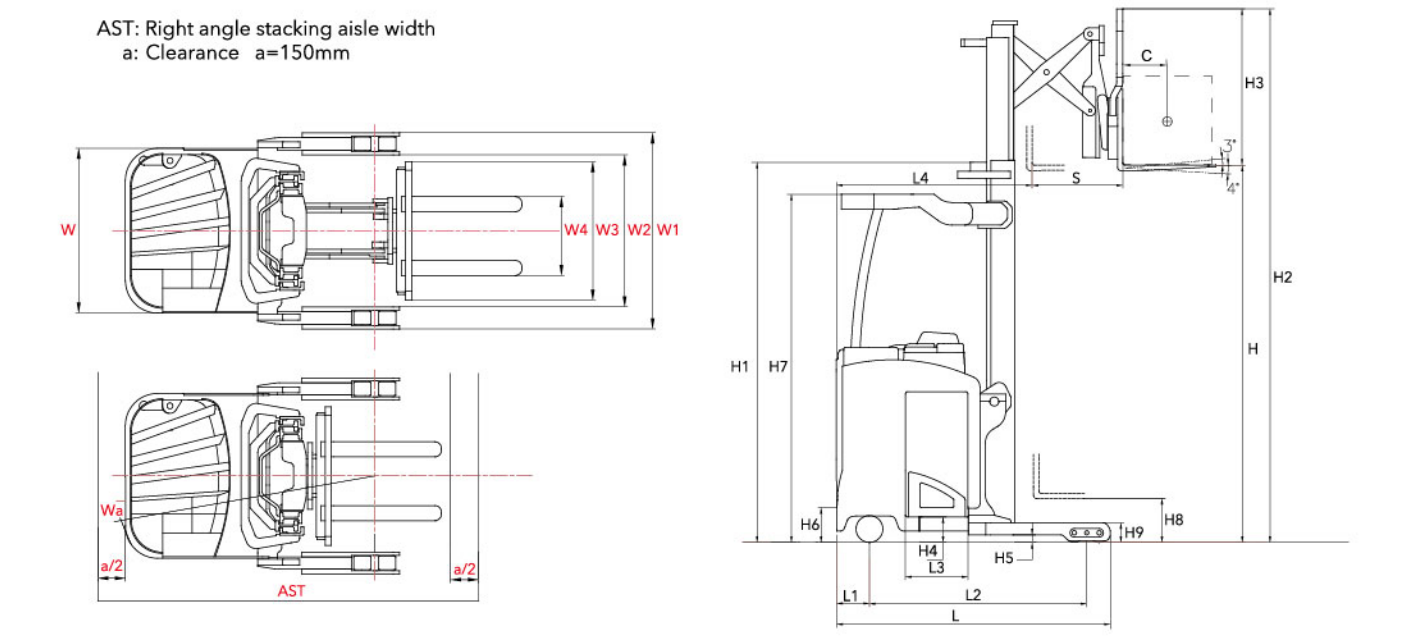

NOTE:The vertical axis is the load capacity,and the horizontal axis is the load center which is calculated from the front face of the forks to the load center of gravity.Capacity curves shown are for a standard mast at zero degree tilt with standard forks.Changing mast tilt,using non-standard forks or loading large goods can affect load capacity.This chart can be used to estimate load capacity at various load centers for standard masts.Contact HELI for specific load ratings for your situation.

THE PERFORMANCE OF BRTRERY INCREASES
Renewable energy technologies **↑15%**
 With the use of AC controlling renewable energy technologies, the forklift is more energy-saving and the working hour of the battery is extended by 15%.

Certifications:These HELI models are CE&CQC certified and also meet all requirements of ANSI B56.1-2012 and OSHA Regulation 29CFR1910.178.All dimensional and performance specifications shown are for reference and subject ti change without notice.