

**8-10 ton  
ENGINE POWERED  
FORKLIFT**

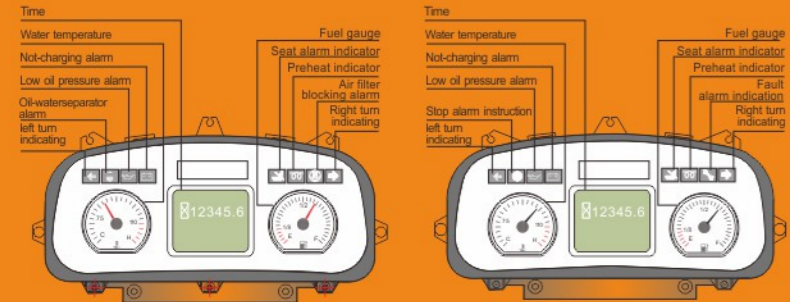

**Reliable special designed instrument**  
The reliable special instrument gives a complete display of the vital information, like operation status, fault detection, etc. It ensures the operator predominate the vehicle status more intuitive and convenient.

- ✓ Stepping motor core
- ✓ Programmable LCD
- ✓ Electrical safety standard meets CE requirements



**8-10 ton  
ENGINE POWERED  
FORKLIFT**

STANDARD EQUIPMENT	OPTIONS
Hour meter	Cab
Horn	Rotating warning light
Oil pressure alarm	Vertical exhaust
Three-spool control valve	Neutral switch
Power steering	Hydraulic circuit oil filter
Rubber pedal pad	Radiator tank
Backrest	Speed-limiting valve
Back view mirror	Oil meter
Front combined lights	Battery-charge indicator
Transmission oil filter	Wide-view mast
Engine flameout device	Intake device
Parking brake cable	Durable tire
Water temperature meter	Operating handles
Attached tools	Traction pin
Rear combined lights	Standard seat
Reversing buzzer	Hudraulic oil gauge
Self-locking tilt valve	Overhead guard raincoat
Tilt adjustable steering column	Torque converter oil gauge
	Combined display
	Tilt cylinder sleeve
	Steering cylinder sleeve
	User-specified color
	Optional attachments

Manufacturer: **ANHUI HELI CO., LTD.**  
NO.668 Fangxing Street, Economical Development Zone,  
Hefei, P.R.China  
TEL:86-551-63639458  
FAX:86-551-63639966  
WEBSITE:HTTP://WWW.CHLFORKLIFT.COM  
E-MAIL:CHL@CHLFORKLIFT.COM

AUTHORIZED DEALER

\* Details of specifications and equipment are based on information available at the time of printing and may change without notice.

**Reliable forklift**

**A reliable Drive system**

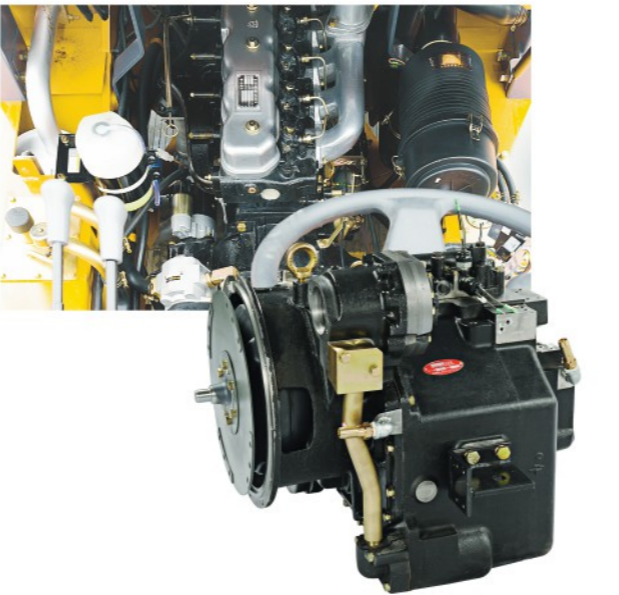

As the most reliable transmission system produced by HELI, it has been validated by over twenty years' experience in the world market. Meanwhile, various ancillary devices of the power system ensure the reliability effectively.

- ✓ Durable transmission
- ✓ Equipped with the intake system
- ✓ Standard distribution of air filter pressure alarm device
- ✓ Automatic engine preheating system
- ✓ Cyclone Air Filter
- ✓ Lost foam casting
- ✓ Various high-power engines are available for customers' optional choices.

**A reliable mast**



The high internal-qualified mast confirmedly ensures the safety of the operator, truck and cargo. Standard configuration of the wide-view mast enlarges operators view effectively, and ensures loading /unloading operations more reliable.

- ✓ Using the best German steel material for triplex mast
- ✓ The frame of mast has more strength basing on the enlarged channel interface.



**A reliable hydraulic system**

HELI has the most professional R&D base of cylinders, where we take advantage of the advanced manufacturing technologies and detecting means to ensure the reliability of all cylinders of the hydraulic system.

- ✓ Standard tilt cylinder by HELI
- ✓ Standard lift cylinder by HELI
- ✓ Standard steering cylinder by HELI
- ✓ Self-locking tilt cylinder
- ✓ Standard hydraulic circuit filter
- ✓ Speed buffer device on lifting system



**A reliable steering system**

The steering system with new technologies not only provides a smoother swerve and faster positioning & steering, but also effectively ensures operators' safety.

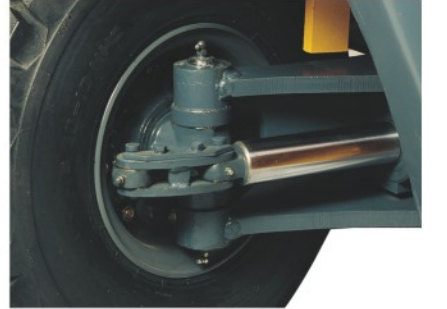

- ✓ Full hydraulic power steering
- ✓ Smaller turning radius
- ✓ Wearable tire

**Comfortable operation space**

Large operation space with ergonomic-design and configuration ensure the operation more comfortable & convenient, and effectively enhance the efficiency & safety of operation.

- ✓ Newly patented insulation materials of Bonnet
- ✓ Well-designed non-slip mat
- ✓ Special display with easily reading
- ✓ Standard files packet
- ✓ Standard distribution of overhead guide raincoat
- ✓ Filled with noise-reducing and buffer rubber material between bonnet and frameworks





Manufacturers Data and Design Characteristics										
Characteristics										
1	Manufacturer			ANHUI HELI CO., LTD.						
2	Model			CPCD80		CPCD100		CPCD80	CPCD100	
3	Power unit					Diesel				
4	Rated Capacity	kg		8000		10000		8000	10000	
5	Load Center	mm				600				
6	Operation			Driver Seated						
Dimensions										
7	Overall max.lifting height (with backrest)	h4	mm	4430		4085		4360	4085	
8	Max.lifting height	h3	mm			3000				
9	Height mast retracted(uptight)	h1	mm	2700		2850		2700	2850	
10	Free lift height	h2	mm			200				
11	Backrest height(from upper face of forks)	h8	mm	1360		1015		1360	1015	
12	Overhead Guard clearance(from face of seat)	h7	mm			1120				
13	Overall height(overhead guard)	h6	mm	2560		2560		2560	2560	
14	Overall length(with forks)	L1	mm	5160		5480		5160	5480	
15	Overall length(without forks)	L2	mm	3940		4260		3940	4260	
16	Front overhang	X	mm	700		718		700	718	
17	Rear overhang	L4	mm	740		740		740	740	
18	Wheel base	L5	mm	2500		2800		2500	2800	
19	Coupler height	h5	mm	540		540		540	540	
20	Min.ground clearance under mast	m1	mm	245		245		245	245	
21	Overall width	B	mm	2165		2165		2165	2165	
22	Lateral fork adjustment outside of fork(Max./Min.)	R	mm	2000/340		2140/410		2000/340	2140/410	
23	Tread(front)	S	mm	1600		1600		1600	1600	
24	Tread(rear)	P	mm	1700		1700		1700	1700	
25	Outside turning radius	Wa	mm	3700		3900		3700	3900	
26	Inside turning radius	V	mm	200		200		200	200	
27	Min.intersecting aisle	Ra	mm	3310		3540		3310	3540	
28	Tilting angles(forward/backward)	$\alpha$ $\beta$				6° / 12°				
29	Fork dimensions(axbxc)	mm		70×1220×170		80×1220×175		70×1220×170	80×1220×175	
Performance										
30	Max. Traveling speeds(With/Without load)	km/h		26/30		26/30		26/28	26/30	
31	Lifting Speeds(With/Without load)	mm/s		440/470		360/380		400/440	330/370	
32	Lowering Speeds(With/Without load)	mm/s				≤600/≥300				
33	Max. Draw-bar pull,With load	kN		60		58		59	57	
34	Max. Negotiable Gradient(With/Without load )	%		27/20		22/20		25/20	21/20	
Weights										
35	Service Mass	kg		10960		12510		10960	12510	
36	Load Wheel with load(Front/Rear)	kg		17000/1960		20380/2130		17000/1960	20380/2130	
37	Load Wheel without load(Front/Rear)	kg		4840/6120		5700/6810		4840/6120	5700/6810	
Tyres										
38	Wheels number front/rear(x=driven)					4x/2				
39	Tyre Type					PNEUMATIC TYRE				
40	Tyre size(front)					9.00-20-14PR				
41	Tyre size(rear)					9.00-20-14PR				
42	Service Brake					Hydraulic-Foot Pedal			Hydraulic-Foot Pedal	
43	Parking Brake					MECHANICAL-HAND BRAKE ROD			MECHANICAL-HAND BRAKE ROD	
Drive										
44	Battery (Voltage/Capacity)	V/Ah				2x12/80		2x12/80		
45	Internal Combustion Engine Model					Cummins QSB4.5		Perkins 1104D-44TA		
46	Engine type					Electronic controlling, Turbocharged,Air-to-air intercooled diesel engine		Turbocharged,Air-to-air intercooled diesel engine		
47	Internal Combustion Engine Rated Output	kW/rpm				82/2200		83/2200		
48	Internal Combustion Engine Rated Torque	Nm/rpm				488/1500		418/1400		
49	Internal Combustion Engine Number of Cylinder					4		4		
50	Internal Combustion Engine Displacement	L				4.5		4.4		
51	Internal Combustion Engine Fuel Tank Capacity	L				140		140		
52	Transmission type					Power Shift		Power Shift		
53	Transmission Number of Speed Fwd/Bwd					2/2		2/2	2/2	

Engine Model and Main Specification for Option					
Internal Combustion Engine Model	Engine type	Internal Combustion Engine Rated Output kW/rpm	InternalCombustion EngineRated torque Nm/rpm	InternalCombustion Engine Displacement L	InternalCombustion Engine Numberof Cylinder
ISUZU 6BG1	Normally Aspirated	82/2000	415/1400-1600	6.494	6
XICHAI CA6110	Normally Aspirated	83/2000	450/1400-1500	7.127	6

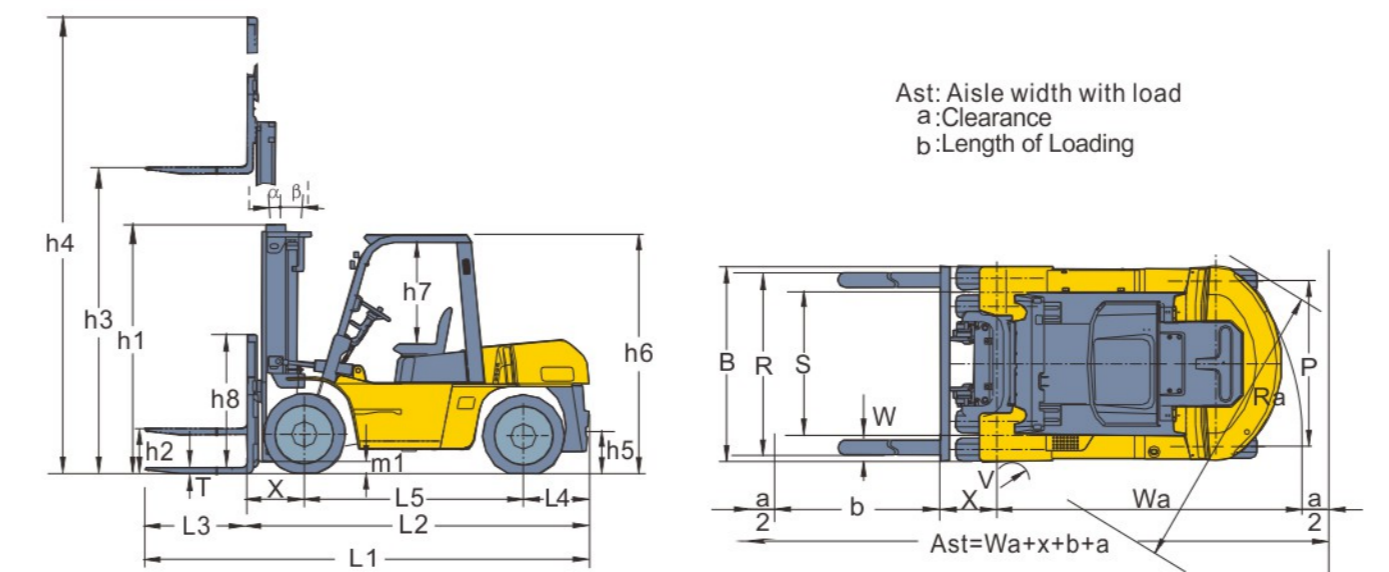

CPCD80 CPCD100

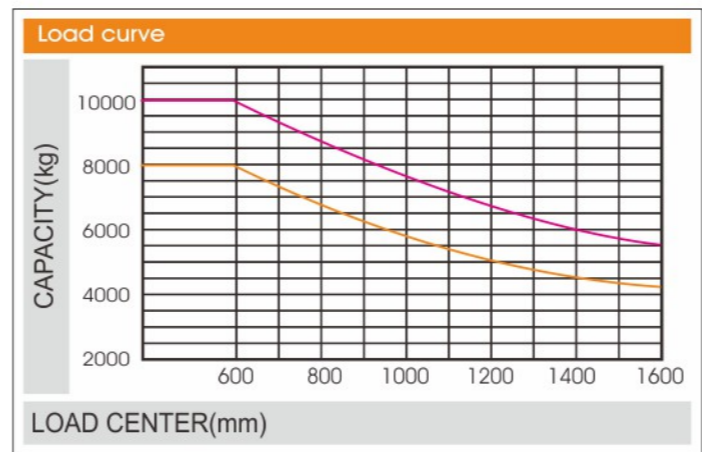

Note:  
Capacities shown are computed with upright in vertical position. Based on a 1000 mm cube load configuration with the center of gravity at the true center of the cube, and standard forks. Truck capacities with upright in forward tilt position will be less. Long forks, and unusually wide or loads may also reduce capacity.

SIDE SHIFTER ON 10T FREE LIFTING MAST					
Mast model	Max. Fork Height (mm)	Load Capacity (kg)	Overall Mast Height (At Lowered) (mm)	Tilting Angle Fwd/Bwd (deg.)	Service Weight (kg)
ZSM360	3600	8000	2570	6-12	12580
ZSM400	4000	8000	2700	6-12	12640
ZSM435	4350	8000	2820	6-12	12700
ZSM480	4800	7500	2970	6-6	12760
ZSM500	5000	7500	3035	6-6	12810
ZSM540	5400	7000	3225	3-6	12880
ZSM600	6000	6000	3425	3-6	12960

8-10t WIDE VIEW MAST								
Mast model	Max. Fork Height (mm)	Load Capacity (kg)		Overall Mast Height (At Lowered) (mm)		Service Weight (kg)		Tilting Angle (deg.)
		CPCD80	CPCD100	CPCD80	CPCD100	CPCD80	CPCD100	
M250	2500	8000	-	2450	-	10870	-	6-12
M270	2700	8000	-	2550	-	10920	-	6-12
M300	3000	8000	10000	2700	2850	10960	12150	6-12
M330	3300	8000	10000	2850	3000	11020	12215	6-12
M350	3500	8000	10000	2950	3100	11060	12260	6-12
M375	3750	8000	10000	3075	3225	11100	12310	6-12
M400	4000	8000	10000	3250	3400	11310	12450	6-12
M425	4250	8000	10000	3375	3525	11360	12510	6-12
M450	4500	8000	10000	3500	3650	11400	12560	6-12
M475	4750	7750	10000	3625	3775	11450	12620	6-6
M500	5000	7750	10000	3750	3900	11500	12670	6-6
M550	5500	7400	9000	4050	4200	11740	12910	3-6
M600	6000	7000	8000	4300	4450	11830	13020	3-6

8-10t WIDE VIEW FULL FREE 3-STAGE MAST										
Mast model	Max. Fork Height (mm)	Load Capacity (kg)		Overall Mast Height (At Lowered) (mm)		Service Weight (kg)		Free lift with Backrest (mm)		Tilting Angle Fwd/Bwd (deg.)
		CPCD80	CPCD100	CPCD80	CPCD100	CPCD80	CPCD100	CPCD80	CPCD100	
ZSM360	3600	7000	8000	2450	2570	11350	12580	1092	1310	6-12
ZSM400	4000	7000	8000	2575	2700	11420	12640	1217	1440	6-12
ZSM435	4350	7000	8000	2700	2820	11490	12700	1342	1560	6-12
ZSM480	4800	7000	7500	2850	2970	11570	12760	1492	1710	6-6
ZSM500	5000	7000	7500	2950	3035	11640	12810	1592	1775	6-6
ZSM540	5400	6600	7000	3075	3225	11710	12880	1717	1965	3-6
ZSM600	6000	6000	6000	3375	3425	12050	12960	2017	2165	3-6
ZSM650	6500	5500	5600	3600	3595	12150	13250	2242	2335	3-6
ZSM700	7000	4500	-	3750	-	12240	-	2392	-	3-6

NOTE: #FREE LIFTING HEIGHT WITHOUT LIFT-BRACKET +213mm(10t without backrest)