



5-7.5 Ton
BALANCE WEIGHT TYPE
FORKLIFT

Standard configuration

- Hour meter
- Horn
- Oil pressure alarm
- Control valve (two piece)
- Wholly hydraulic powered steering
- Rubber pad
- Backrest
- Rearview mirror
- Front combined lamp
- Transmission oil filter
- Engine flameout device
- Cable type parking brake
- Water temperature gauge
- Driver's tool
- Rear combined lamp
- Backward buzzer
- Tilt cylinder self lock valve
- Tilting adjustable steering column

Optional Devices and Accessories

- Overhead guard
- Standard fork
- Neutral switch
- Hydraulic oil return circuit filter
- Flow regulator
- Oil lever gauge
- Charging indicator
- Wide view mast
- Air intaking device
- Durable tread tyre
- Lifting and tilting operation lever
- Traction pin
- Standard seat
- Hydraulic oil dipstick
- Overhead guard rain cover
- Torque converter oil dipstick
- Combined instrument

- Driver's cab
- Rotating alarming light
- Upper air exhausting device
- Double air cleaner
- Lengthening fork extension
- Warm air blower
- Solid tyre
- Widen fork arm carrier
- Windshield
- Cleansing muffler
- Fire extinguisher muffler
- Fire extinguisher
- Rear working light
- Air conditioner (Certain type)
- Torque converter oil temperature gauge
- Tilting cylinder bush
- Steering cylinder bush

- Customer made color
- Optional attachments

Manufacturer: **ANHUI HELI CO., LTD.**
NO.688 Fangxing Street, Economical Development Zone,
Hefei, P.R. China
TEL: 86-551-63639458
FAX: 86-551-63639966
WEBSITE: HTTP://WWW.CHLFORKLIFT.COM
E-MAIL: CHL@CHLFORKLIFT.COM

AUTHORIZED DEALER

* Details of specifications and equipment are based on information available at the time of printing and may change without notice.



5-7.5 t
Internal Combustion
Counterbalanced Forklift Truck

5-7.5 t

Internal Combustion
Counterbalanced Forklift Truck

Reliable forklift Reliability is based on first-class manufacturing technology.

New steering handwheel adjusting mechanism



With patented technology of new steering handwheel double thread adjusting mechanism improving operating comfort and adjusting reliability.

Reliable lifting system



High quality mast ensuring operating safety; Wide view mast fitted as standard with good view.

- ✓ World-first class quality U-steel from Germany
- ✓ Enlarged U-steel cross-section to achieve firm structure

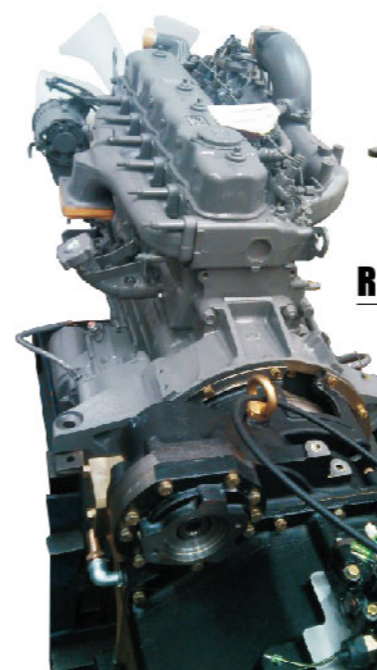

Reliable power system

The HELI transmission box specialized for the truck mode which is the most reliable transmission system in HELI with 20 years market proof effectively reduce trouble rate. Meanwhile, a number of power-assisted devices are assembled to ensure the system reliability.

- ✓ Transmission box working continually without trouble for 800 hours on average
- ✓ Lost foam casting box
- ✓ Upper air intaking system
- ✓ Air cleaner pressure alarm device
- ✓ Engine automatic preheating system
- ✓ Whirlwind air cleaner

Reliable special instrument



- ✓ Reasonable structure featuring Integration of instrument and steering column to achieve good view.
- ✓ Easy control of working condition through kinds of alarm indicators on the meter such as water temperature, oil lever, hour meter and so on.

Reliable steering system

The steering system adopting new technology not only ensure steady steering, quick positioning and steering, but also ensure the driver's safety.



- ✓ Wholly hydraulic steering
- ✓ Small steering radius
- ✓ Durable tyre

Air intaking system

Air suction inlet installing on top of the overhead guard brace far away from the dust produced when travelling. Cleaner air sucked prolonging engine service life.

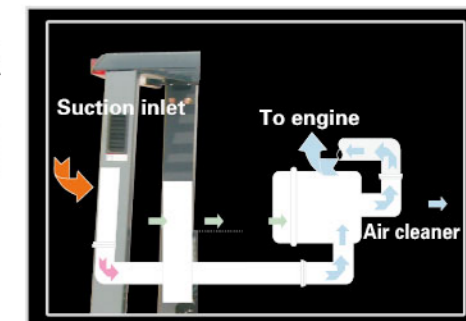

Manufacturers Data and Design Characteristics										
Characteristics										
1.1	Manufactory		ANHUI HELI CO., LTD.							
1.2	Model		CPCD50	CPCD60	CPCD70	CPCD75	CPCD50	CPCD60	CPCD70	
1.3	Type		Diesel Oil				Diesel Oil			
1.4	Capacity	kg	5000	6000	7000	7500	5000	6000	7000	
1.5	Load Center	mm	600							
1.6	Driving mode		Sit-on type				Sit-on type			
Size										
2.1	Overall max.lifting height (with backrest)	h4	4400	4400	4400	4290	4400	4400	4400	
2.2	Max.Lifting height	h3			3000			3000		
2.3	Height mast retracted(upright)	h1	2500	2500	2500	2567	2500	2500	2500	
2.4	Free lift height	h2			200			200		
2.5	Backrest height(from upper face of forks)	h8			1355			1355		
2.6	Overhead Guard clearance(from face of seat)	h7			1120			1120		
2.7	Overall height(overhead guard)	h6	2450	2450	2450	2510	2450	2450	2450	
2.8	Overall length(with forks)	L1	4625	4700	4780	4965	4625	4700	4780	
2.9	Overall length(without forks)	L2	3405	3480	3560	3745	3405	3480	3560	
2.10	Front overhang	X	590	595	600	655	590	595	600	
2.11	Rear overhang	L4	565	635	710	840	565	635	710	
2.12	Wheel base	L5	2250	2250	2250	2250	2250	2250	2250	
2.13	Coupler height	h5	430	430	430	430	430	430	430	
2.14	Min.ground clearance under mast	m1	200	200	200	267	200	200	200	
2.15	Overall width	B	1995	1995	1995	1995	1995	1995	1995	
2.16	Lateral fork adjustment(Outside of fork)	R	1845/300	1845/300	1845/300	1845/300	1845/300	1845/300	1845/300	
2.17	Front thread	S	mm	1470	1470	1470	1470	1470	1470	
2.18	Rear thread	P	mm	1700	1700	1700	1700	1700	1700	
2.19	Outside turning radius	Wa	mm	3250	3360	3400	3250	3300	3360	
2.20	Inside turning radius	V	mm	200	200	200	200	200	200	
2.21	Min.intersecting aisle	Ra	mm	2960	3000	3040	2960	3000	3040	
2.22	Tilting angles(forward/backward)		6°/12°				6°/12°			
2.23	Fork size	mm	55×1220×150	60×1220×150	65×1220×150	70×1220×150	55×1220×150	60×1220×150	65×1220×150	
Performance										
3.1	Max. Traveing speeds (laden/unladen)		26/28	26/28	26/28	24/29	26/30	26/30	26/30	
3.2	Lifting Speeds (laden/unladen)		480/530	480/530	480/530	430/480	450/470	440/470	430/470	
3.3	Lowering Speeds (laden/unladen)		≤600/≥300							
3.4	Max. Draw-bar pull (laden)		54	54	54	54	42	40	40	
3.5	Max. Gradeability(laden/unladen)		35/20	32/20	30/20	25/20	23/19	20/19	20/19	
Weight										
4.1	Service Mass		8130	8720	9320	10100	8130	8720	9320	
4.2	Load Wheel.laden(Front/Rear)		11790/1340	13120/1600	14550/1770	15130/2470	11790/1340	13120/1600	14550/1770	
4.3	Load Wheel.unladen(Front/Rear)		4090/4040	3920/4800	3850/5470	3780/6320	4090/4040	3920/4800	3850/5470	
5.1	Wheel(Front/Rear) X=Driving Wheel		4X/2				4X/2			
5.2	Tyre(Front/Rear)		Pneumatic tyre				Pneumatic tyre			
5.3	Tyre size (front)		4-8.25-15-14PR				4-8.25-15-14PR			
5.4	Tyre size (rear)		2-8.25-15-14PR				2-8.25-15-14PR			
5.5	Service Brake		Power brake-pedal type				Power brake-pedal type			
5.6	Paking Brake		Mechanism-hand braking rod type				Mechanism-hand braking rod type			
Drive and transmission control device										
6.1	Battery Voltage/Capacity		2x12/80				2x12/80			
6.2	Internal Combustion Engine Model		A-6BG1QC-02				Mitsubishi S6S-T(Euro IIIA,EPATier III)			
6.3	Engine type		Diesel engine				Diesel engine			
6.4	Internal Combustion Engine Rated Output		82/2000				63.9/2300			
6.5	Internal Combustion Engine Rated Torque		415/1400-1600				285/1700			
6.6	Internal Combustion Engine Number of Cylinder		6-105*125				6-94x120			
6.7	Internal Combustion Engine Displament		6.494				4.29			
6.8	Internal Combustion Engine Fuel Tank Capacity		140				140			
6.9	Transmission Number of Speed Fwd/Bwd type		2/2- POWER SHIFT				2/2- POWER SHIFT			

Engine Model and Main Specification for Option					
Internal Combustion Engine Model	Engine type	Internal Combustion Engine Rated Output kW/rpm	Internal Combustion Engine Rated torque Nm/rpm	Internal Combustion Engine Displacement L	Internal Combustion Engine Number of Cylinder
XICHA CA6110	Diesel Engine	83/2000	450/1400-1500	7.127	6

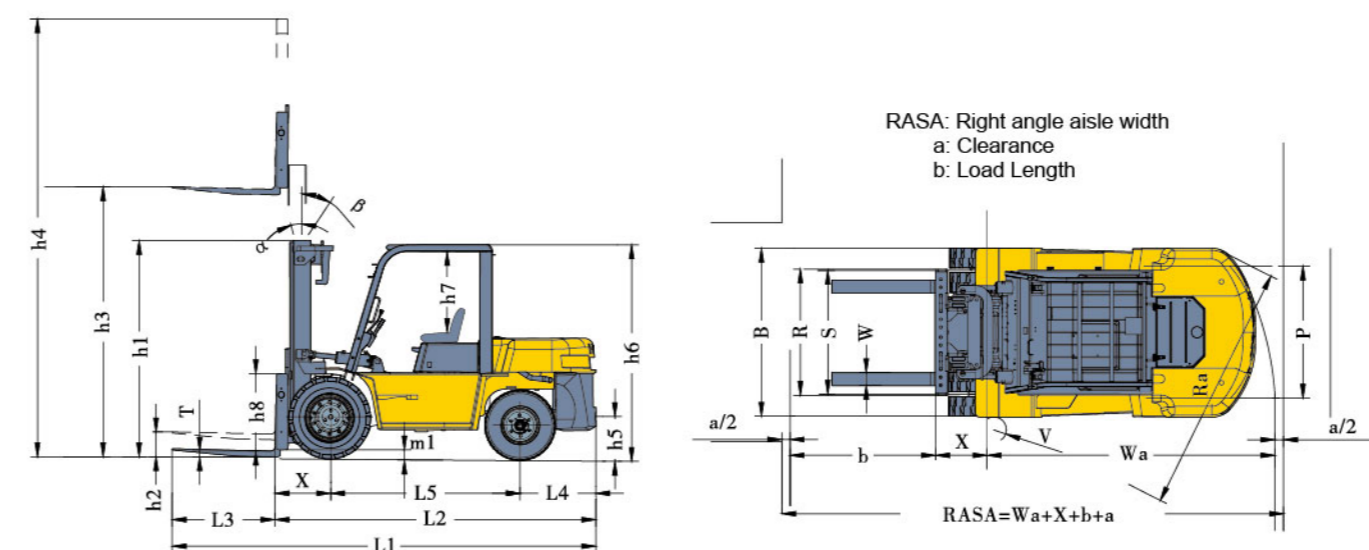

Meter function diagram

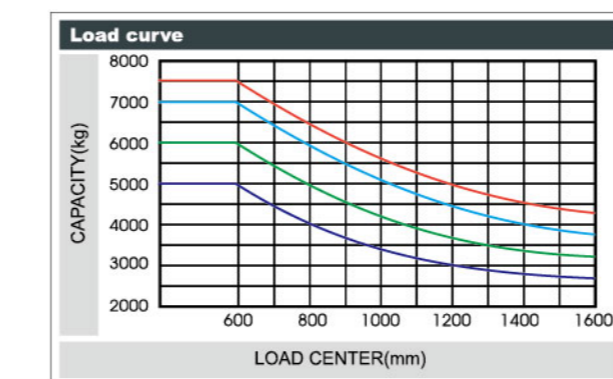
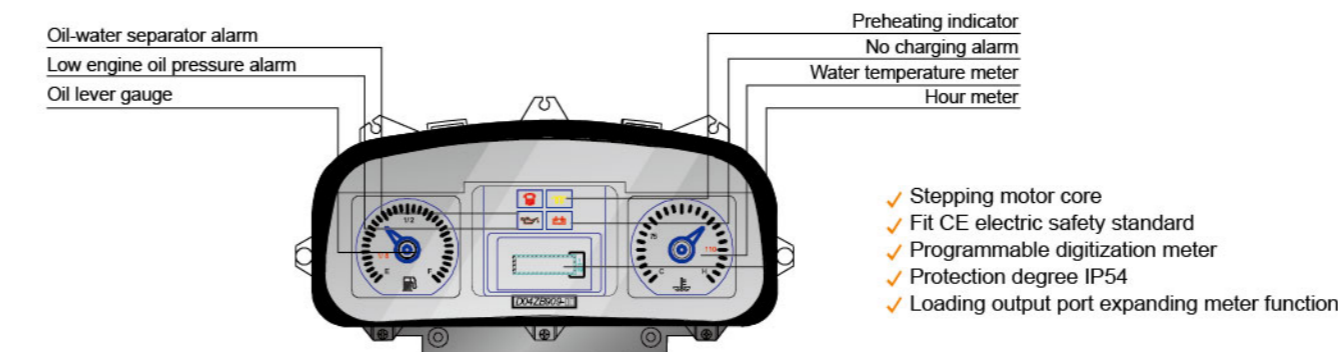

5-7.5t WIDE VIEW MAST														
Mast type	Max. Lifting height (mm)	Loading capacity (load center 500mm) (kg)				Mast overall height (Fork to the ground)(mm)				Service weight (With backrest)(kg)				Mast tilting angle Forward/Backward (deg.)
		CPCD50	CPCD60	CPCD70	CPCD75	CPCD50	CPCD60	CPCD70	CPCD75	CPCD50	CPCD60	CPCD70	CPCD75	
M200	2000	5000	6000	7000	-	2000	-	7836	8496	9206	-	-	6-12	
M250	2500	5000	6000	7000	7500	2250	2317	7900	8560	9270	9991	-	6-12	
M270	2700	5000	6000	7000	7500	2350	2417	7930	8590	9300	10013	-	6-12	
M300	3000	5000	6000	7000	7500	2500	2567	7980	8640	9350	10040	-	6-12	
M330	3300	5000	6000	7000	7500	2650	2717	8030	8690	9400	10089	-	6-12	
M350	3500	5000	6000	7000	7500	2750	2817	8060	8720	9440	10118	-	6-12	
M375	3750	5000	6000	7000	-	2875	-	8100	8760	9480	-	-	6-12	
M400	4000	5000	6000	7000	7500	3050	3117	8270	8930	9650	10328	-	6-12	
M425	4250	5000	6000	7000	7500	3175	3242	8310	8970	9690	10368	-	6-12	
M450	4500	5000	6000	7000	7500	3300	3367	8350	9010	9730	10409	-	6-12	
M475	4750	5000	6000	7000	-	3425	-	8390	9050	9770	-	-	6-6	
M500	5000	5000	6000	7000	7500	3550	3617	8430	9090	9810	10490	-	6-6	
M550	5500	4750	5700	6600	7000	3850	3917	8630	9290	10000	10684	-	3-6	
M600	6000	4400	5400	6400	6700	4100	4167	8710	9370	10080	10766	-	3-6	

Note: optional mast tilting angle for K7.5t with mast lower than 4m: forward 10. /backward 12.

5-7t WIDE VIEW FULL FREE 2-STAGE MAST														
Mast type	Max. Lifting height (mm)	Loading capacity (load center 500mm) (kg)				Mast overall height (Fork to the ground)(mm)				Service weight (With backrest)(kg)			Free lift (with backrest) (mm)	Mast tilting angle Forward/Backward (deg.)
		CPCD50	CPCD60	CPCD70		CPCD50	CPCD60	CPCD70	CPCD50	CPCD60	CPCD70			
ZM250	2500	5000	6000	7000	2210	8010	8670	9380	840	6-12				
ZM270	2700	5000	6000	7000	2310	8040	8700	9410	940	6-12				
ZM300	3000	5000	6000	7000	2460	8090	8750	9460	1090	6-12				
ZM330	3300	5000	6000	7000	2610	8140	8800	9510	1240	6-12				
ZM350	3500	5000	6000	7000	2710	8170	8830	9540	1340	6-12				
ZM375	3750	5000	6000	7000	2835	8210	8870	9580	1465	6-12				
ZM400	4000	5000	6000	7000	3010	8370	9030	9740	1640	6-12				
ZM425	4250	5000	6000	7000	3135	8410	9070	9780	1765	6-12				
ZM450	4500	5000	6000	7000	3260	8450	9110	9820	1890	6-12				
ZM475	4750	5000	6000	7000	3385	8490	9150	9860	2015	6-6				
ZM500	5000	5000	6000	7000	3510	8530	9190	9900	2140	6-6				
ZM550	5500	4750	5700	6600	3810	8730	9390	10100	2440	3-6				
ZM600	6000	4400	5400	6400	4060	8810	9470	10180	2690	3-6				

Note: 5-6t truck without backrest free lifting height: +465mm
7t truck without backrest free lifting height: +310mm

5-7t WIDE VIEW FULL FREE 3-STAGE MAST														
Mast type	Max. Lifting height (mm)	Loading capacity (load center 500mm) (kg)				Mast overall height (Fork to the ground)(mm)				Service weight (With backrest)(kg)			Free lift (with backrest) (mm)	Mast tilting angle Forward/Backward (deg.)
		CPCD50	CPCD60	CPCD70		CPCD50	CPCD60	CPCD70	CPCD50	CPCD60	CPCD70			
ZSM360	3600	4500	5600	6200	2335	8670	9330	10020	910	6-6				
ZSM400	4000	4500	5600	6200	2470	8730	9390	10080	1040	6-6				
ZSM435	4350	4500	5600	6200	2585	8790	9450	10120	1156	6-6				
ZSM450	4500	4500	5600	6200	2635	8820	9480	10150	1205	6-6				
ZSM480	4800	4500	5600	6200	2740	8890	9640	10310	1310	6-6				
ZSM500	5000	4500	5600	6200	2805	9010	9670	10340	1380	3-6				
ZSM540	5400	4200	5300	6000	2940	9080	9740	10510	1510	3-6				
ZSM600	6000	4000	5000	5600	3140	9170	9830	10690	1710	3-6				
ZSM650	6500	3500	4500	5000	3405	9280	9940	10810	1975	3-6				
ZSM700	7000	3200	4000	4500	3515	9390	10050	10920	2085	3-6				

Note: 5-6t truck without backrest free lifting height: +465mm
7t truck without backrest free lifting height: +310mm